

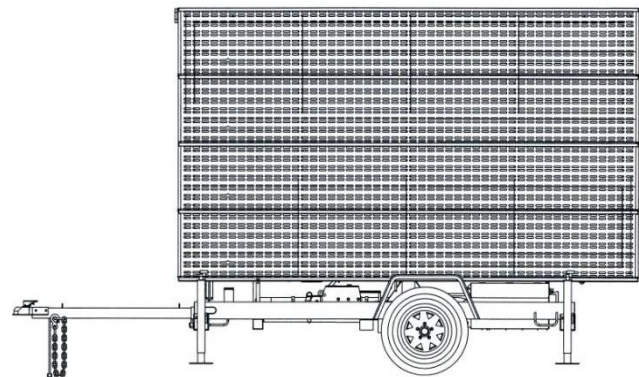

AMERICAN SIGNAL COMPANY
2755 Bankers Industrial Dr.
Atlanta, GA 30360
Phone: 770-448-6650
Fax: 770-448-8970

Models T331 / T332 / T333 Service and Maintenance Manual

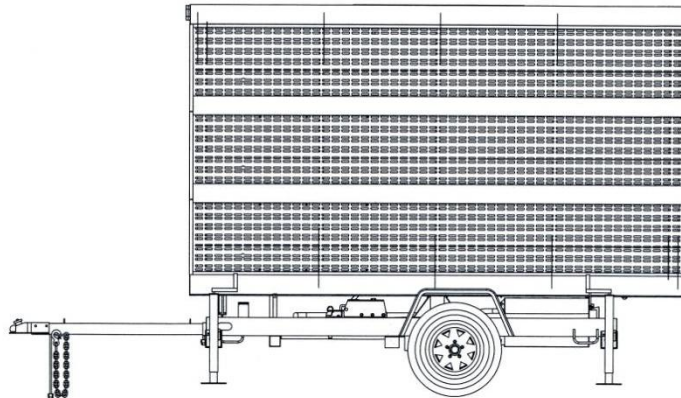
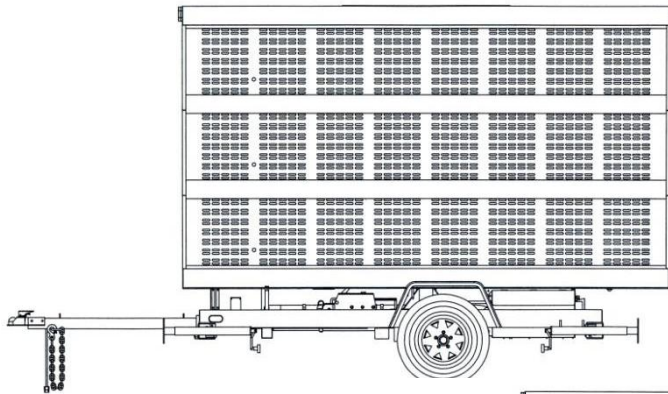

Document #: MAN00000096
Revision: C
Date: 10-31-2017



AMERICAN SIGNAL COMPANY
2755 Bankers Industrial Dr.
Atlanta, GA 30360
Phone: 770-448-6650
Fax: 770-448-8970

AMERICAN SIGNAL COMPANY
Amsig® Limited Warranty

Limited Warranty. Amsig® warrants all portable changeable message signs against manufacturing defects in materials and workmanship for one year from the date of shipment from Amsig®'s factory. Within this period Amsig® will repair or replace equipment returned to the factory prepaid, without charge for parts and labor. After repair or replacement, Amsig® will ship the equipment back to the Buyer by the same mode or type of delivery used by the Buyer to send the equipment to Amsig® (overnight courier, same class of mail or UPS delivery, freight line, etc.).

This limited warranty does not cover (a) damage or failure caused by or attributable to acts of God, abuse, misuse, improper or abnormal usage, faulty installation, improper maintenance, lightning or other incidents of excessive voltage; (b) any repairs other than those provided by an Amsig® authorized service facility; or (c) transportation costs other than as provided above.

Certain components of the equipment are covered by warranties from manufacturers other than Amsig®. Copies of those warranties will be delivered to the Buyer along with the equipment. Amsig® has no liability for and does not provide warranty service for these items, which include engine, battery or batteries, battery charger, hydraulic pump system, tires, wheels, axles, brakes, and trailer hitch (if any). The Buyer should consult the applicable manufacturer for a specific warranty regarding a specific component. Amsig®'s limited warranty does not cover any damages to parts otherwise covered by Amsig®'s limited warranty if and to the extent that such damages are caused by or result from a defective or malfunctioning item warranted by another manufacturer.

Amsig®'s limited warranty obligation shall be automatically suspended upon the Buyer's failure to pay any obligation owed to Amsig® according to the terms agreed upon between them (whether pursuant to this Quotation or any other agreement between them). Such suspension shall continue until the Buyer has paid such obligation in full. Notwithstanding the foregoing, Amsig® shall honor its limited warranty obligation for any equipment that has been sold by the Buyer, unless the owner of the equipment is in default under any obligation to pay the Buyer for such equipment.

As owner's sole and exclusive remedy under these warranties, Amsig® shall, in its sole discretion either (i) provide services to repair a nonconformity with these limited warranties, or (ii) replace the nonconforming component of its product. THE FOREGOING IS OWNER'S SOLE AND EXCLUSIVE REMEDY FOR BREACH OF THESE WARRANTIES.

EXCEPT AS PROVIDED ABOVE, Amsig® MAKES NO EXPRESS WARRANTIES. FURTHER, Amsig® MAKES NO WARRANTY OF MERCHANTABILITY AND NO WARRANTY OF FITNESS FOR ANY PARTICULAR PURPOSES WHATSOEVER WITH RESPECT TO THE EQUIPMENT BEING SOLD.

©Copyright 1995-2009, American Signal Company, Inc. All Rights Reserved. No portion of this document may be reproduced in any form without express written permission from American Signal Company



Contents

1.0 Introduction	5
1.1 Part Numbers and Standard Features	6
1.2 Available Options.....	7
2.0 Trailer Transport and Deployment	8
2.1 Charge the Batteries	8
2.2 Tow the Trailer	9
2.3 Level Trailer - Operating Position.....	10
2.4 Raise & Lower Sign Case (Hydraulically).....	11
2.4.1 Raise Sign Case.....	11
2.4.2 Lower Sign Case:	12
2.5 Raise & Lower Sign Case (Manually)	13
2.5.1 Manually Raise Sign Case.....	13
2.5.2 Manually Lower Sign Case	13
2.6 Install/Remove Tongue Assembly or Remove Hitch.....	14
2.6.1 Install the Tongue Assembly	14
2.6.2 Remove the Tongue Assembly.....	14
2.6.3 Remove the Hitch	14
3.0 T33X Series Major Components/Parts Guide	15
3.1 Sign Case Assembly.....	15
3.2 Battery Box	17
3.3 Cylinder	19
3.4 Solar Panel Assembly	19
3.5 Pedestal Assembly.....	20
3.6 Tires & Axle.....	22
3.7 Tongue Assembly.....	22
3.8 Leveling Jacks	23
3.9 Spare Parts List	24



4.0 33x WX Series Maintenance 25

4.1 Sign Case Assembly Maintenance..... 25

4.2 Hydraulic Pump Maintenance..... 26

4.3 Solar Panels 27

4.4 Battery Maintenance 27

4.5 SEASONAL STORAGE..... 30

4.6 Mast 30

5.0 Wiring Diagrams..... 31

5.1 Model T331 System Wiring..... 32

5.2 Model T332 System Wiring..... 33

5.3 Model T333 System Wiring..... 34

6.0 Mechanical Drawings 35

7.0 Trouble Shooting..... 36

8.0 Service Contact 37

Revision Information

Rev.	Date	Author	Description	Page
A	1-1-13	Price R. Potter	Initial Release	-
B	7-1-13	Price R. Potter	Add note to turn off Solar switch before servicing Display Panels (Sec. 3.3), Update 30065208-WIR drawing (Sec. 5.1)	18, 27
C	11-1-17	Kevin Sampler	Total update	



1.0 Introduction

The information contained in this manual describes the 33x Series Portable Changeable Message Sign (PCMS). The American Signal model numbers for these 33x Series of PCMS products are:

- T331, T331E, S331
- T332, T332E, S332
- T333, T333E, S333

The differences between the model designators are:

- T – Trailer-mounted with standard trailer length and power configuration
- T & E – Trailer-mounted with Extended length and Expanded power configuration
- S – Stationary, not mounted on a trailer

These models use the same display panel with a 5x7 matrix, however they are arranged differently in each one. The different configurations of the LED display panels are illustrated in the following chart:

Model #	Sign Case size	LED Configuration			
		Matrix	Rows	Columns	Pixel
T331	79.5" High x 137.5" Wide	Character	21	40	4 LEDs/Pixel
T332	79.5" High x 137.5" Wide	Line	21	50	4 LEDs/Pixel
T333	79.5" High x 137.5" Wide	Full	28	50	4 LEDs/Pixel

See Section 6.0 for a visual representation of each sign case and the display panel configuration. A more complete list of the standard features and available options for each model is contained in the next subsections.

Detailed information on the operation and programming of the PCMS software is contained in MAN00000095 Software Operations Manual, 33x WX.



1.1 Part Numbers and Standard Features

The following tables and charts describe the various standard configurations and features that are present with the T33x models.

Model #	Top-level Part #	# of 6V Batteries	# of 80W Solar Panels
T331E	AMS30065208	8	2
T331	AMS30065211	6	1
T332E	AMS30065248	8	2
T332	AMS30065251	6	1
T333E	AMS30065268	8	2
T333	AMS30065271	8	2

The following is a list of the standard features on all 33x WX models:

- Highway Orange/Flat Black color
- 18" high, 5x7 matrix, 4 LEDs/pixel
- DynaPoint Lens
- 6V batteries (see chart above)
- 80W solar panels (see chart above)
- 75A charger
- Bolt-On mast
- Low-profile NEMA 4 style pedestal enclosure
- Hand-held terminal
- 2" removable pinned-on ball hitch
- Removable tongue
- Hydraulic surge brake
- Hydraulic pump & cylinder (for raising/lowering sign)
- Leveling jacks (4x)

NOTE: All of the above information (standard battery and solar as well as standard features) is subject to change at the discretion of American Signal Company.



1.2 Available Options

While specific options and option part numbers change for each model, all of the T33x models can be configured with the following upgrades:

Expanded battery bank

Expanded solar array

Aimstar adjustable solar array

Remote operation via cell phone modem communication

Global Positioning System

Radar overspeed detection

Spare tire

Outrigger jacks

Tongue-mounted jack

Electric or hydraulic brakes

Physical security features

Highway Advisory Radio

Extended warranties and Preventive Maintenance Agreements

Wide variety of hitches and tail light connections

Optional trailer color

Wide variety of ITS applications

Contact your Amsig sales representative or the Amsig Service Department for option information, availability, and pricing for your specific model.



2.0 Trailer Transport and Deployment

2.1 Charge the Batteries

Before deployment, it is necessary to ensure that the battery electrolyte level is properly maintained and that the voltage level is above 12VDC. If battery voltage is below 11.2VDC the PCMS display will not operate. It will be necessary to recharge the batteries with 120VAC (from a landline or generator) before operating the PCMS. Fully charged batteries will be 13.2-13.6VDC

The solar-assisted battery power supply system furnished with the 33x Series PCMS includes multiple deep-cycle 6V batteries which are uniquely able to withstand the deep discharges that occur periodically during normal operation. The system has been designed to provide sign operation over all of the usable state of charge level of the batteries.

Depending upon several factors (i.e. length & duration of message displayed, the brightness level, the number of solar panels, the amount of available sunlight, the number of batteries, the age of the batteries and the ambient temperature), voltage level of the battery pack can eventually drop below 11.2VDC, and the PCMS display will stop operating. At that time (or sooner, if desired), it will be necessary to recharge the batteries with 120VAC (from a landline or generator). An abbreviated summary of steps to charge the batteries with the provided 75A charger is shown below (for detailed battery maintenance instructions see Section 4.4):

- Turn the PCMS system off at Main Power or Sign Display switch. (Note: The system can be left on during charging, however, it will require more time to fully recharge the batteries)
- Bring 120VAC to trailer and plug into covered receptacle on right side of pedestal assembly.
- Apply AC power to trailer until onboard ammeter reads 0 (typically 2-3 days, depending on the size of your battery bank).
- When batteries are fully charged, unplug 120VAC power source from pedestal. Batteries are fully charged when the specific gravity with a temperature compensated hydrometer is 1.25 +.010.

In dealing with batteries, great care should be taken during their handling, charging, and maintenance. More detailed information on aspects of, and precautions for, charging batteries is provided in the Maintenance section and Specification section.

2.2 Tow the Trailer

Prior to actually towing the trailer, additional steps must be taken to ensure that the unit is ready and safe for travel:

- Crank up and rotate horizontal all Jacks
- Lower the sign case assembly
- Engage the sign case brake

Raise and stow the rear leveling jacks (this makes it easier to engage/disengage the towing tongue to the hitch). In order to keep the horizontal jacks within the footprint of the trailer, rotate each jack with the foot facing toward the fender and that the crank handle is collapsed onto the jack. Ensure that the lock pin snaps into position when the jack is horizontal.



Remove the locking pin from the locking lever on the trailer hitch.
Lift the locking lever on the trailer hitch



Locking Pin

Position the hitch receiver over the towing vehicle ball hitch and lower the hitch to firmly seat around the ball.

Push the locking lever down to engage the lock.

Insert the locking pin through the hole in the lever to prevent accidental unlocking.

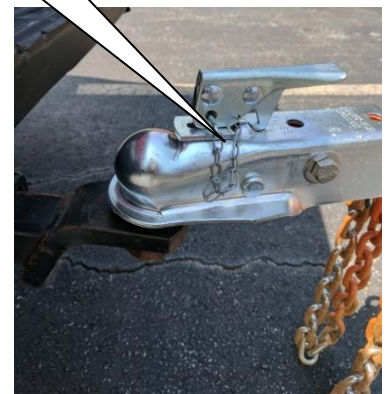
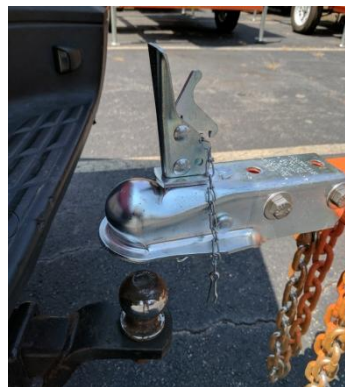



Attach the safety chains to the appropriate attach points on the towing vehicle



Attach the electrical connector from the tongue assembly to the electrical connector on the towing vehicle (for tag, trailer, and brake lights).

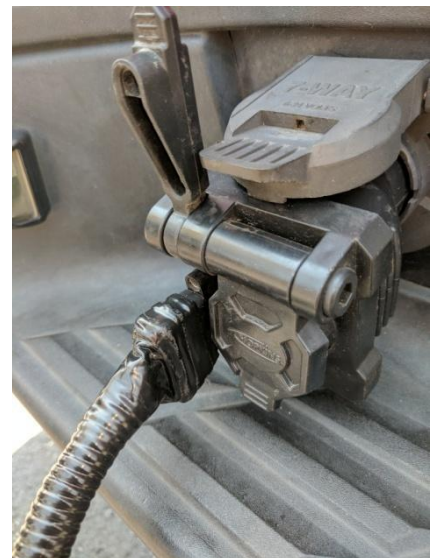

2.3 Level Trailer - Operating Position

To level the trailer, pull the spring-loaded lock pin and rotate jacks to the down position. Crank the handle at the top of each jack to extend the support leg and foot down to the ground/pavement. Adjust extension of four jacks as needed to level the trailer.

2.4 Raise & Lower Sign Case (Hydraulically)

2.4.1 Raise Sign Case

Under normal operating conditions, the sign case is raised and lowered via the hydraulic pump and cylinder mechanism. To raise the sign case, perform the following steps:

Loosen the both brake band rods on the mast assembly with the provided closed-end ratchet (located in the bottom front of the pedestal assembly). Failure to loosen both brake bands before attempting to raise the PCMS may cause damage to the unit.

Toggle the “Up-Down” switch on the dash panel in pedestal assembly to the upper position. **DO NOT TAKE THE RODS ALL THE WAY OUT.**

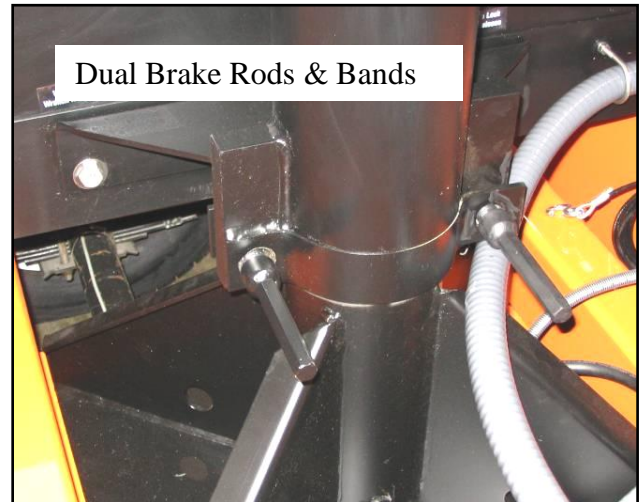

The operator can place a hand on the sign case as it is raised to avoid unwanted rotational movement due to wind or trailer tilt.

When the cylinder has reached its maximum extension, the sign case will stop (with an audible thump). Slide the safety pin, chained to the outer mast, through the two holes in the inner mast. It will be necessary to stand on the trailer frame to reach the safety pin and inner mast holes. The safety pin will stop the sign case from failing in the event of cylinder malfunction or loss of hydraulic pressure.

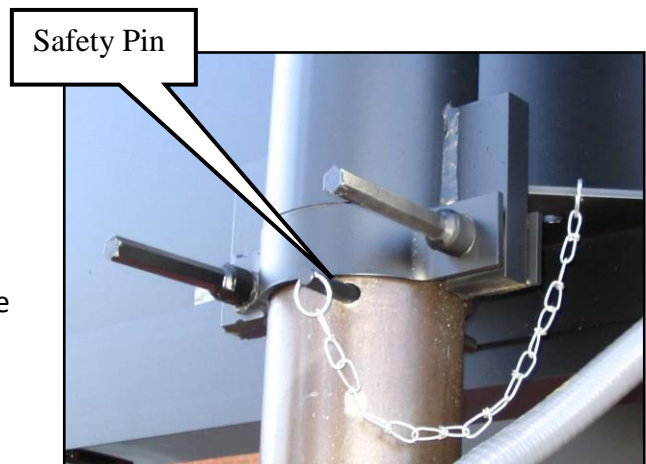

- Once the safety pin is in place, the sign case should be lowered to rest on the pin. The sign case is free to rotate more than 360 degrees and can now be aimed in the desired direction by utilizing the sight tube mounted to the bottom of the sign case.
- After the PCMS is oriented correctly, use the ratchet to tighten both brake band rods thereby preventing the sign case from rotating.



2.4.2 Lower Sign Case:

- Use the ratchet to loosen the both brake band rods.
- Toggle the “Up-Down” switch on the dash panel to the upper position to lift the sign case off of the safety pin.
- Remove safety pin from inner mast and replace in hole in outer mast bracket.
- Rotate the PCMS so as to orientate the sign face to the side of the trailer and away from the pedestal assembly and above the cradle platforms on the trailer deck.
- Toggle the “Up-Down” switch on the dash panel to the lower position to begin lowering the sign case.

It may be necessary to place a hand on the sign case as it is lowered to avoid unwanted rotational movement due to wind or trailer tilt. It is important that the sign case be guided downward so as to not be lowered onto the trailer pedestal assembly potentially causing damage or injury. Continue guiding the sign case down until it rests on the front and rear cradle rubber strips on the trailer deck (travel position).

After the PCMS is oriented correctly on the battery box, use the ratchet to tighten both brake band rods, thereby preventing the sign case from being jarred out of travel position. The sign case must be in the cradle and both brake band rods must be tightened prior to towing the trailer.



Sign Case Front Cradle



Sign Case Rear Cradle



2.5 Raise & Lower Sign Case (Manually)

In the event that the hydraulic pump does not activate through the switch it can be manually operated to raise and lower the sign case. To manually raise or lower the sign, follow all of the steps involved in hydraulically moving it up and down, plus do the following:

2.5.1 Manually Raise Sign Case

- Open the split lid on the battery box (the side that does not have the sign case cradle)
- Insert the pump handle (mounted in battery box next to pump) into the manifold on the side of the Pump.
- Push the pump handle back & forth to force hydraulic fluid into the cylinder, thereby raising the sign.

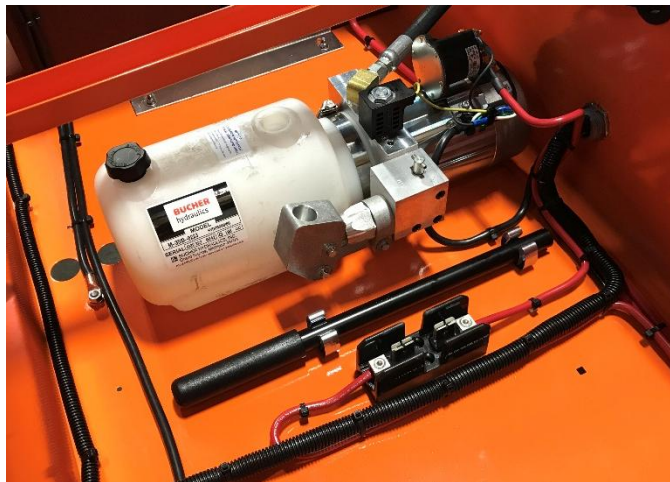

2.5.2 Manually Lower Sign Case

- Open the split lid on the battery box (the side that does not have the sign case cradle)
- Place notch in end of pump handle over T-handle valve on top of pump.
- Rotate the pump handle in small increments to release hydraulic pressure in the cylinder and lower the sign.



2.6 Install/Remove Tongue Assembly or Remove Hitch

2.6.1 Install the Tongue Assembly

In order to reduce the space needed to transport the trailers, the tongue assembly may be shipped uninstalled. To install the tongue assembly:

- Remove the 1" diameter pin from the frame.
- Align rear of tongue assembly with sleeve in front of trailer and insert tongue until hole in tongue lines up with hole in rear sleeve.
- Reinsert 1" diameter pin thorough mating holes.
- Reinstall the safety clip in the bottom of the pin
- Connect mating trailer light connectors on tongue and trailer together.

2.6.2 Remove the Tongue Assembly

The tongue assembly can also be removed to inhibit theft of the trailer. To remove the tongue assembly:

- Remove 1" diameter pin from the trailer frame.
- Unplug mating trailer light connectors on tongue and trailer.
- Pull tongue assembly forward until tongue comes completely out of the sleeve.
- Reinsert 1" diameter pin thorough hole in the trailer frame
- Reinstall the safety clip in the bottom of the pin



2.6.3 Remove the Hitch

Instead of removing the entire tongue assembly, the hitch can be removed individually to inhibit theft of the trailer. Due to size and weight considerations, removal of the hitch is sometimes a more appropriate method of preventing theft. To remove the hitch:

- Remove cotter pins (2x) from hitch pins (2x).
- Slide hitch pins out of hitch.
- Remove the hitch from tongue tube.



3.0 T33X Series Major Components/Parts Guide

The T33x Series standard components and their functions are briefly described in this section. References to and pictures showing specific brands of equipment are included for discussion purposes only. All brands, equipment, and designs are subject to change at any time without notice. Wiring diagrams, mechanical drawings, part numbers, and technical specifications are contained in other sections. (NOTE: P/Ns with revisions are denoted with an “-x” suffix. Call factory for applicable or current revision level.)

3.1 Sign Case Assembly

The sign case assembly provides the housing for many of the major PCMS components, including the display panels with DynaPoint lenses, central processing unit (CPU), solar booster/regulator and silk-screened lens. See the Trailer Operation section for information on accessing the internal components of the sign case.

Display Panel

The display panel contains the LEDs with DynaPoint lens, and is mounted to the rails behind the display lens. The DynaPoint lens is mounted to each pixel (4 LEDs) and focuses the amber light from each LED to provide a more concentrated and brighter beam of light. The display panels are connected to the CPU in columns with a front-mounted Mass Termination Assembly (MTA) connector providing power and data to each panel.

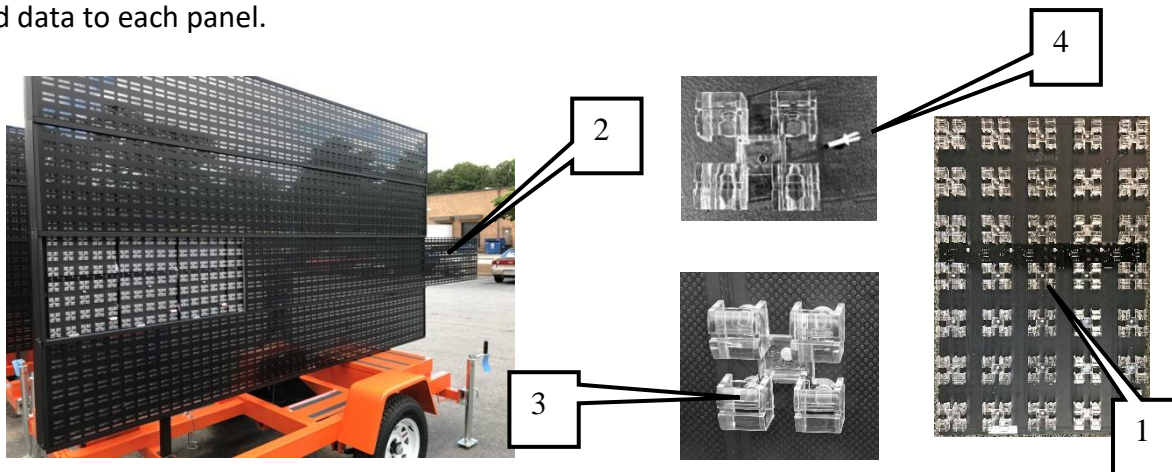

#	Part Description	Part Number
1	18" display panel LEDs 30°	PNL385-801
1A	LED 30°	DIO295
2A	Silk-screened lens T331	AMS30120023
2B	Silk-screened lens T332 & 333	AMS30120024
3	DynaPoint lens	LEN102
4	Rivet	RIV2085

Silk Screened Lens

The silk-screened lens is a 3/16" UV-protected clear polycarbonate with black silk-screening to provide contrast, to reduce glare, and to protect the LEDs.

Equipment Tray

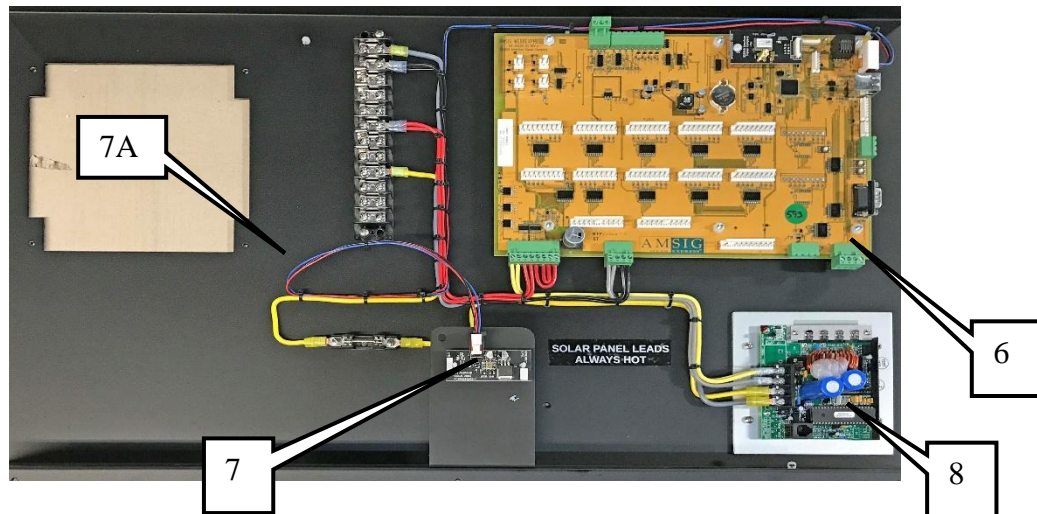

Central Processing Unit

The CPU is the “brain” of the PCMS and is located on the equipment tray on the left side of the sign case behind the bottom row (331 & 332) or second from bottom row (333) of display panels. The CPU provides power and data to the display panels, monitors solar and battery charging, and is connected to the hand held terminal through the umbilical

Photosensor Board

The photosensor board is also located on the equipment tray and faces forward through the display lens. The photosensor is the device that measures the amount of ambient light that is present at the PCMS. This value is correlated to a brightness level in the DIM table and allows control of the LEDs to be brighter or dimmer as current conditions require.

#	Part Description	Part Number
6	CPU	40-00100-01
7	Photosensor board	PCB-265-x
7A	Photosensor light harness	HAR625
8	Solar booster	CEL-135

3.2 Battery Box

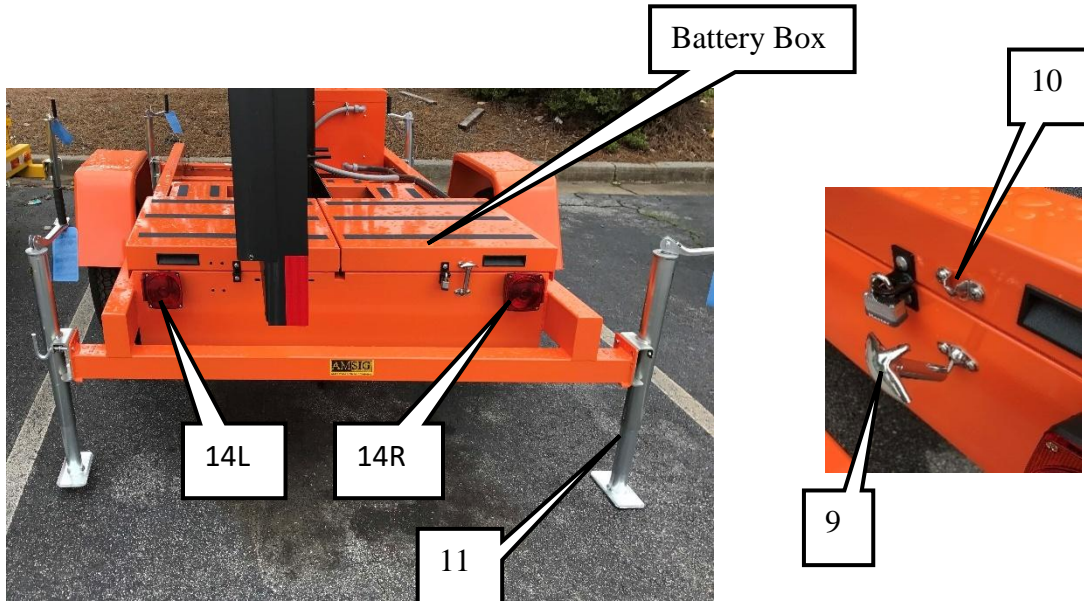

Batteries

The 33x series trailers are populated with 6V batteries wired parallel/series to provide 12VDC to the sign.

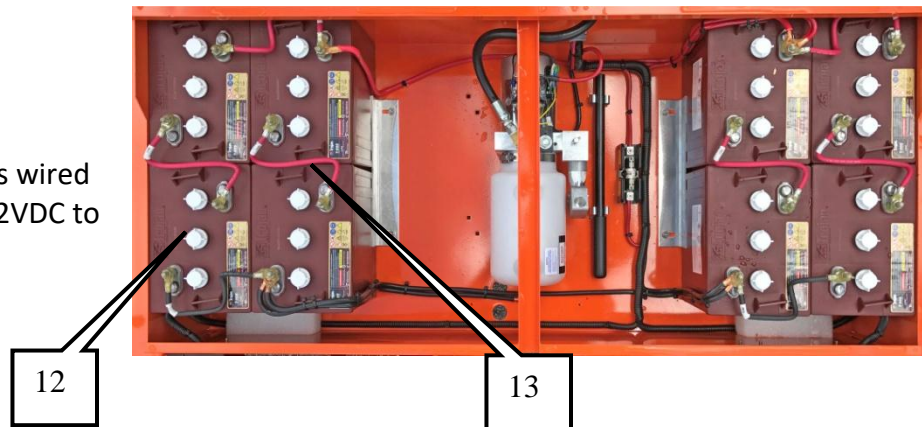

#	Part Description	Part Number
9	Latch	LAT-70
10	Hook	LAT-80
11	Leveling jack	JAC-85
12	Battery	BAT-140
13	Battery cables (various lengths and colors)	Call Amsig Service
14L	Lamp, tail left side	LAM20
14R	Lamp, tail right side	LAM30

The hydraulic pump and cylinder provide the lifting mechanism to raise (for deployment) and lower (for travel and storage) the sign case.

Hydraulic Pump

The hydraulic pump is a 12VDC pump and hydraulic reservoir that provides the hydraulic pressure to the cylinder to raise and lower the sign case assembly. The pump is mounted in the battery box and the “Up-Down” toggle switch that controls it is located in the pedestal assembly dash panel. In the event that the hydraulic pump malfunctions, it can be manually operated to raise and lower the sign case.

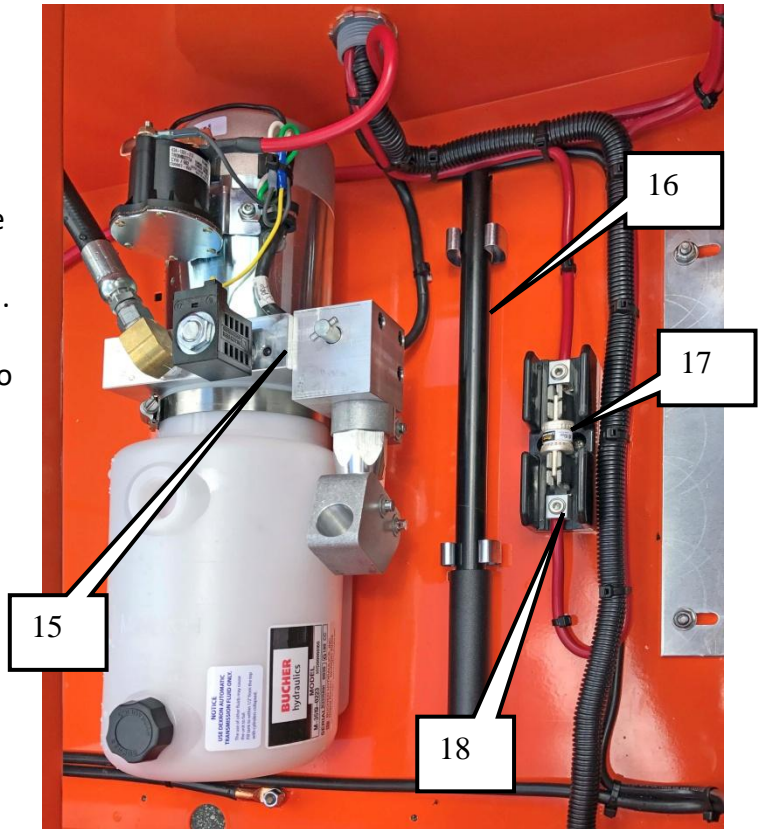

#	Part Description	Part Number
15	Hydraulic pump	HYD-160
16	Manual pump handle	HYD-171
17	Fuse	FUS-325
18	Fuse holder	FUS-315
	Hydraulic fluid – available at local auto parts stores	Any Automatic Transmission Fluid (ATF) can be used



3.3 Cylinder

The lifting cylinder is located inside of the mast assembly and is connected to the pump by a hydraulic hose and fittings assembly. As the cylinder extends and retracts, the sign case is raised and lowered.

3.4 Solar Panel Assembly

The solar panels convert sunlight into electrical power (12VDC) to maintain the charge state of the batteries. This re-charging of the batteries allows the PCMS to operate over a longer period of time before requiring landline (or generator) 120V charging. See Specifications section for more information on the solar panel.

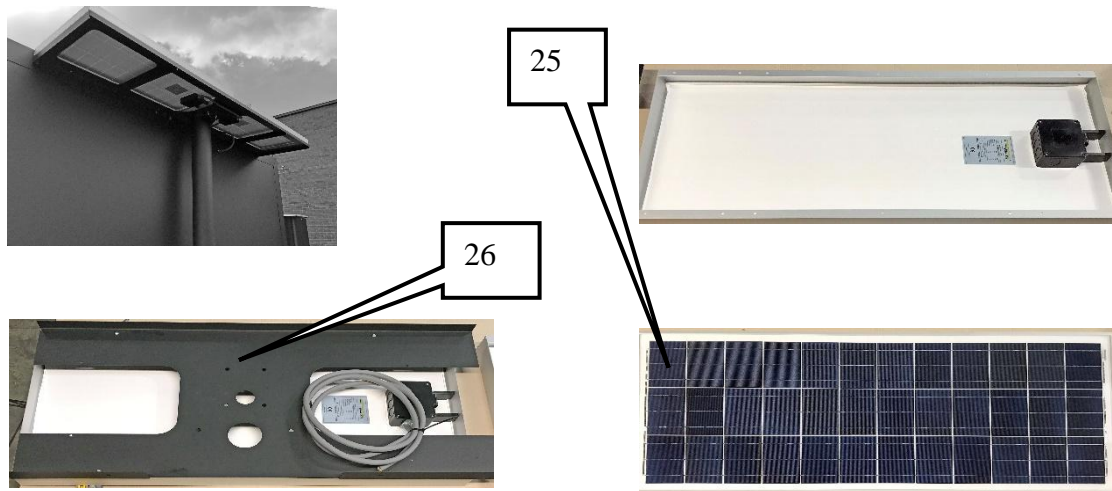

#	Part Description	Part Number
25	Solar panel	CEL-120
26A	Solar panel assembly, single	AMS30045045
26B	Solar panel assembly, double	AMS30045041

3.5 Pedestal Assembly



The pedestal assembly is a double-flange NEMA-style enclosure that is pad lockable and contains the following major components:

Dash Panel

The dash panel contains the sign display “On-Blank” switch, the “Up-Down” toggle switch, battery ammeter and “Push To Reset” 10A fuse. The “On-Blank” switch provides a means of overriding the current message to display no message (blank) without requiring “password” entry into the sign control menu functions. This “blank” mode does not interrupt the solar charging of the batteries.

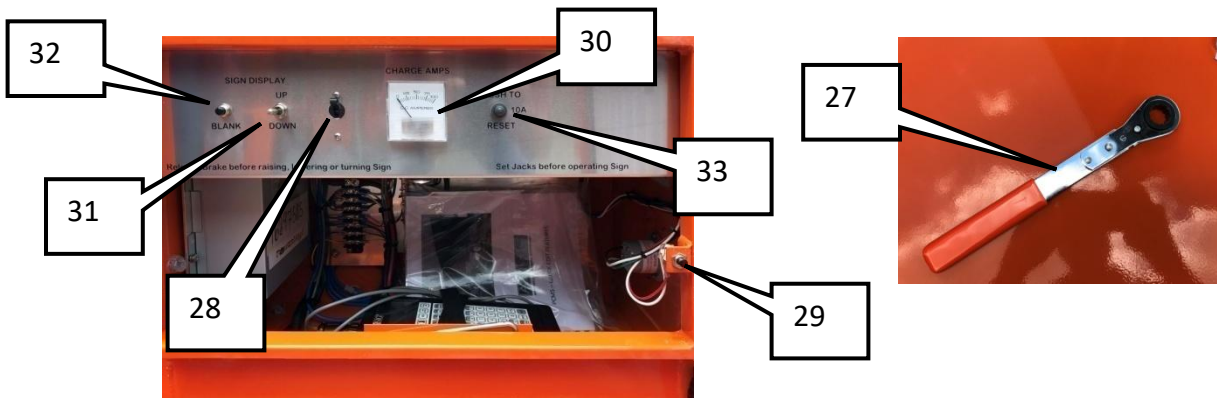

#	Part Description	Part Number
27	Wrench	WRE-10
28	Power switch	SWI-585
29	Courtesy light switch	SWI-70
30	Ammeter	MET-125
31	Hydraulic UP/DOWN switch	SWI-20
32	Blank switch	SWI-70
33	Hydraulic reset	SWI-590
34	Courtesy lamp (behind dash panel)	LAM-40
35	AC sense relay (behind dash panel)	REL126



Charger

A 75-amp charger unit is provided that converts landline 120VAC to 12VDC for charging of the batteries.

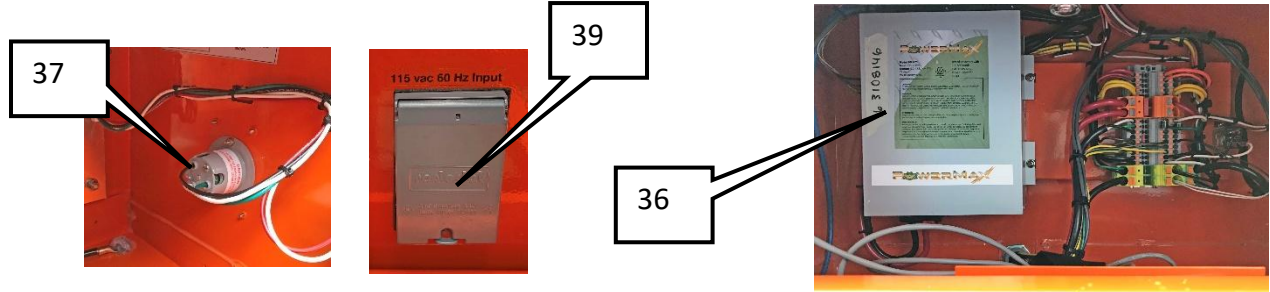

#	Part Description	Part Number
36	75A charger/converter	CHG-155
37	120VAC receptacle	CON-490
38	Handheld terminal	TER-105
39	Receptacle cover	COV-10
40	Umbilical assembly	AMS30121992

Hand-held Terminal

The handheld terminal (HHT) is the device that allows local control of the PCMS and is stored at the bottom of the pedestal assembly. The HHT features a keypad and a backlit LCD display for superior visibility. The HHT is intended to be stored in its cradle inside the pedestal assembly. The HHT's cable is 15' long to allow movement of the operator around the trailer. The HHT can also be detached from the pedestal assembly and stowed in a separate, more secure area. If the terminal is disconnected, the PCMS will continue to operate as previously programmed. The HHT is detached by unscrewing the CPC connector at the top of the terminal.

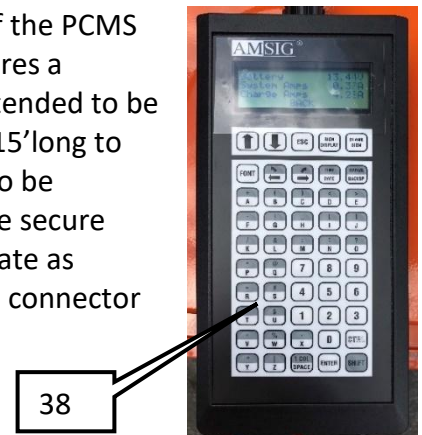

Courtesy Light

A light bulb is located behind the dash panel and shines downward to provide additional light to the pedestal and HHT. A door switch turns the light off when the pedestal door is closed.

Umbilical Assembly

An umbilical assembly connects the sign case and pedestal assembly. This umbilical contains data and power wires and is comprised of watertight, vandal-resistant tubing.





3.6 Tires & Axle

Tires

The tires are 15" 6-ply P 205-75-15 B rated tires and mount to the axle hub with 5 lugs on 4-1/2" centers. They are load rated for 1820 lbs.

Axle

The axle is 3500 lb. rated straight idler with 71" hub face distance and 5 lugs on 4-1/2" centers. The suspension is double eye leaf springs with 56.5" centers.

3.7 Tongue Assembly

The tongue assembly is a removable tongue that allows the trailer to be towed by other vehicles. A 2" lever-style ball hitch that is rated for 5,000 lbs. and is pinned to a 3" square tube is provided as standard. See Trailer Operation section for more information on the tongue assembly and see the Specification section for more information on the hitch.

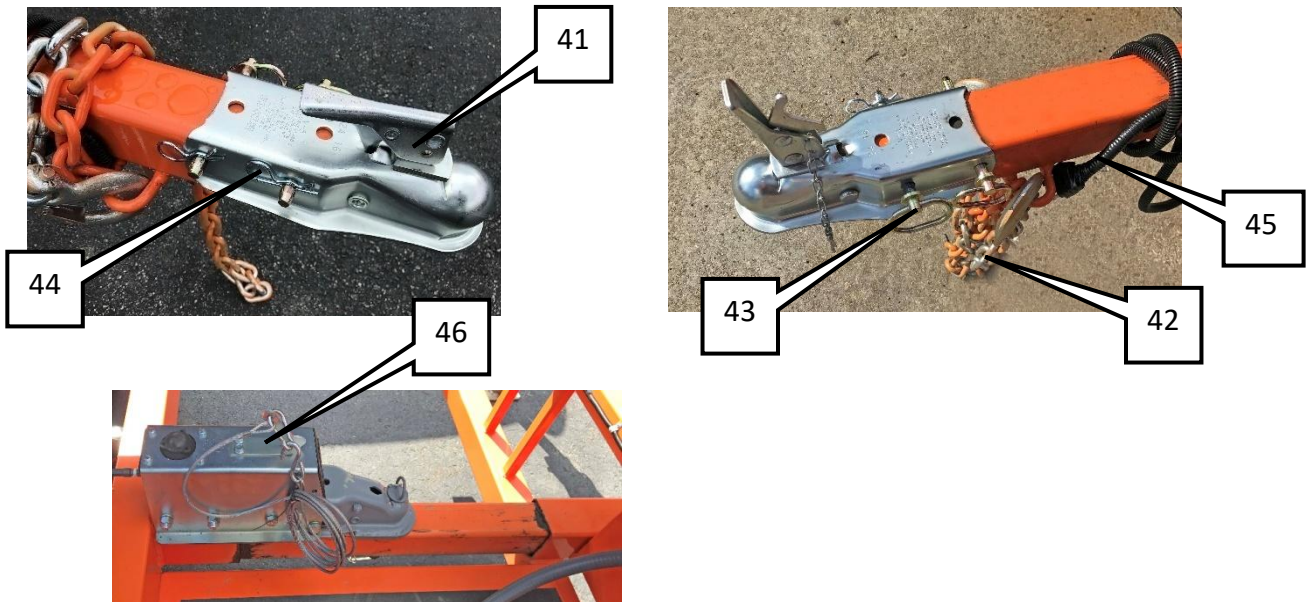

#	Part Description	Part Number
41	2" ball hitch	HIT55-1
42	Safety chains with hooks	AMS30015031
43	Hitch pin	PIN30
44	Cotter pin	PIN130
45	Trailer brake and tail lights harness	HAR195
46	Hitch with optional hydraulic surge brake	HIT-11 (Hit-10 and BRK-30)



3.8 Leveling Jacks

The leveling jacks are located at the four corners of the trailer and are top-wind, swivel-mounted jacks used to level and stabilize the PCMS. The jacks are rated for 2000 lbs each and have a travel range of 15”.

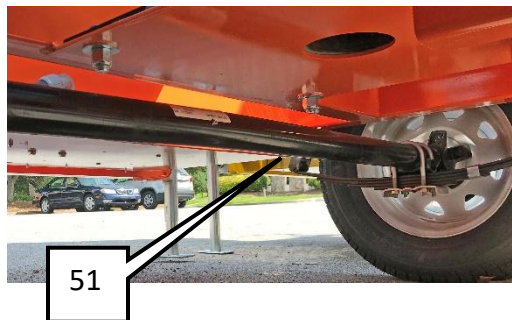
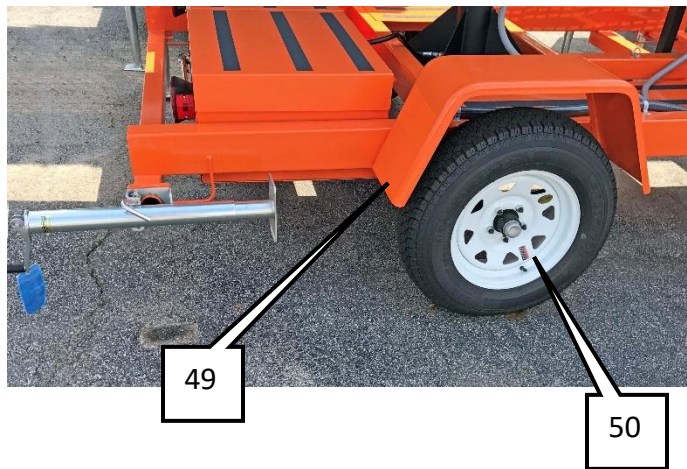

#	Part Description	Part Number
48	Jack 2000# top-wind swivel mount 15”	JAC85
49	33x fender	FEN10
50	Tire/Wheel assembly T33x	WHE10
51	Axle T33x	AXL220



3.9 Spare Parts List

Amsig P/N	Description	T33x models		
		331 331E	332 332E	333 333E
Sign Case Assembly:				
PNL00000385-x	Display Panel, 18" 5x7 4LED/Pixel T33x	•	•	•
40-00100-01	Board, CPU WebbExpress	•	•	•
PCB00000265-x	Photosensor Board, LED	•	•	•
AMS30120023	Lens, Silkscreened T331	•		
AMS30120024	Lens, Silkscreened T332/333		•	•
Hydraulic Pump and Cylinder:				
HYD00000160	Hydraulic Pump, Combo 12V + Lever	•	•	•
HYD00000181	Cylinder, Hydraulic 1-1/2 Bore 57" Stroke	•	•	•
Solar Panel Assembly:				
CEL00000120	Solar Panel, 80W @17.1V	•	•	•
Pedestal Assembly:				
TER00000105	Terminal, Handheld Keyboard "98"	•	•	•
CHG00000155	Charger, 75/80A 120V 13.2V to 14.4V	•	•	•
Trailer Assembly:				
BAT00000140	Battery, 6V Deep Cycle 215 Amp-Hrs	•	•	•
FUS00000325	Fuse, Circuit Breaker 90A	•	•	•
WHE00000010	Wheel, Tire F78-15ST 6 Ply 1820#	•	•	•
AXL00000220	Axle, 3500# 71" Hubs Hydraulic	•	•	•
HIT00000011	Hitch, w/Hydraulic Surge Brake	•	•	•
AMS30040318	Tongue Assembly with hitch	•	•	•
HIT00000055-1	Hitch, 2" Ball Socket Lever w/Pin	•	•	•
JAC00000085	Jack, 2000# Top Wind Swivel Mount 15"	•	•	•
LAM00000020	Lamp, Tail Left Side	•	•	•
LAM00000030	Lamp, Tail Right Side	•	•	•
Miscellaneous:				
WRE00000010	Wrench, Box Ratchet 5/8" x 11/16"	•	•	•
BIT00000190	Bit, Torx 1/4" Pin-In-Head Screw	•	•	•

NOTE: P/Ns with revisions are denoted with an "-x" suffix. Call factory for applicable (or current) revision level.



4.0 33x WX Series Maintenance

4.1 Sign Case Assembly Maintenance

The CPU, power manager and any additional communication equipment are located on an equipment tray in the sign case. The display panels are also located in the sign case. The LED display panels do not need maintenance, however if an LED is not operating the panels can be removed and replaced.

To access and replace the LED display panels:

- Turn sign display power OFF by accessing the main “On-Off” power switch on the dash panel.
- Remove the screws holding the end cap closest to the panel to be replaced. Remove end caps from as many rows as need to be accessed.
- Slide the appropriate lens either right or left far enough to get access to the desired display panel.

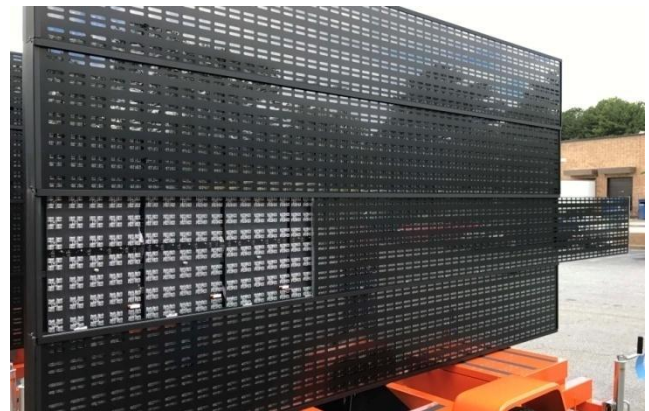

***** CAUTION *****

DO NOT disconnect or reconnect display panels with sign display power or solar power ON.

- Unplug MTA connector on front of panel.

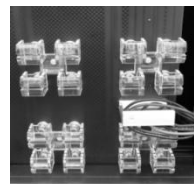

- Remove center screw securing display panel.



- While still in rail groove, lift display panel up and tilt bottom of panel forward.
- Slide display panel down and away from rails.
- Reverse process to install replacement LED display panel.



To access the equipment tray to replace the CPU:

- Turn sign display power OFF by accessing the main “On-Off” power switch on the dash panel.
- Remove the screws holding the end cap on the right side of the silkscreened lens
- On a 331 and 332, remove RH end cap on the bottom lens.
- On a 333, remove RH end cap on the 2nd from bottom lens.
- Slide the lens to the right approximately 3 ft.
- Remove the display panels covering the equipment tray using the LED display panel access procedure.
- Lift clear plastic sheeting covering equipment tray and components.

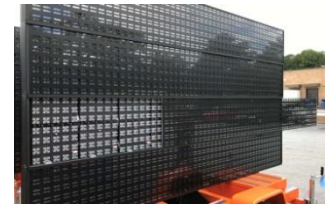

- Disconnect all connections on the CPU.
- Remove the nylon nuts that secure the CPU to the equipment tray.
- Remove the CPU and install the new CPU board on the studs in the equipment tray.
- Reuse the nylon nuts to secure the new CPU board to the equipment.
- Reconnect all electrical connections to the new CPU board.
- To close sign case after accessing the equipment tray or display panels, reverse the steps shown above.

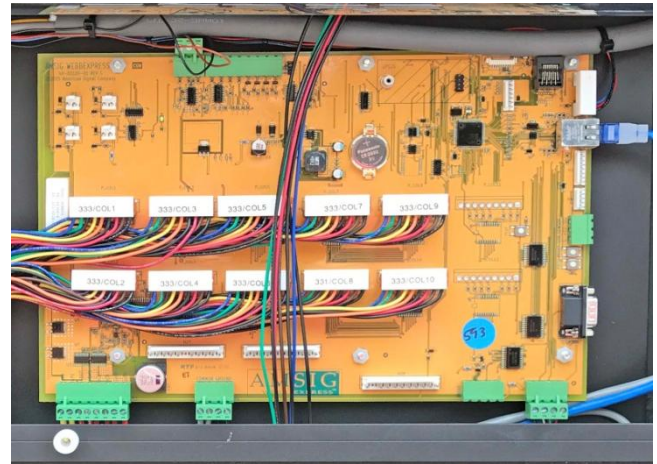

Lens Maintenance

In order to provide maximum visibility and clarity, the lens should be cleaned periodically. It is recommended that the lens be cleaned with a mild soap and water solution, using a soft cloth so as not to scratch the silk-screening.

If the lens is damaged (cracked or severely scratched) or visibility is impaired, it can be removed and replaced. To remove the lens, follow the steps detailed in the LED display panel replacement section. Slide replacement lens into grooves in mounting rails with the silkscreened surface facing out.

4.2 Hydraulic Pump Maintenance

In order for the hydraulic pump to operate correctly, it requires adequate quantities of hydraulic fluid. The level of fluid in the holding tank on the pump should be periodically checked and refilled to 1” below the filler opening if low. Also, check the hose and fittings for leaking and repair if necessary.



4.3 Solar Panels

- To ensure optimal charging capability the solar panel should be exposed to as much sunlight as possible. Storing or deploying your PCMS under a tree, bridge, or other object that restricts sunlight will negatively impact the PCMS run time
- Keep the solar panel's surface clear of debris, dirt, and ice by wiping the surface with a non-abrasive material (such as cloth or paper towels) as necessary.
- Do not scrape the solar panel to remove build-up, as that may damage the solar cells.
- Do not apply industrial type cleaning fluids or solutions to the surface of the solar panel. If a rag or cloth is not sufficient to clean the surface then apply warm water or household type cleaner such as Windex.

4.4 Battery Maintenance

During operation (particularly in the summer months), it is necessary to ensure that the battery electrolyte level is properly maintained.

During the winter months, it is necessary to ensure that the battery state of charge remains above the level necessary to prevent the batteries from freezing. When temperatures below freezing are forecast, test the electrolyte levels in the batteries using a hydrometer. The voltage level alone is not an accurate indicator of electrolyte freezing temperature. A chart in the Specification section shows how to determine electrolyte freezing points at various hydrometer readings. In the event the hydrometer reading shows that the specific gravity of the electrolyte is low enough to allow the batteries to freeze, it may be necessary to recharge them.

Stratification

Stratification occurs when the batteries have not moved over a long period of time and the electrolyte fluid in the battery begins to separate. Stratification results in only the lower parts of the battery cells doing the work causing reduced battery capacity and life. The electrolyte stratification that occurs in wet batteries, standing still at float voltages, can be reduced by inserting the dual voltage plug into the charger. The dual voltage plug allows for occasional fast charging at 14.2VDC and can cause the batteries to bubble for a few hours. Be sure to check and maintain the water levels in the batteries before and after the bubbling charge. After the fast charge, remove the dual voltage plug to avoid boiling the batteries dry. See Specification section for more information on charger.

Stratification does not occur in batteries which are jostled by frequent moving of the vehicle they are mounted in.



Detailed Sequence of Battery Charging Actions

- Make sure you wear protective clothing and a face shield when doing any kind of maintenance or charging of battery system.
- Disconnect battery cables.
- Wash dirt off the top of the batteries.
- Measure the specific gravity of all cells and remove those batteries having more than .050 variation between the cells.
- Reconnect the battery cables to allow charging of those remaining.
- Be sure that all remaining battery cells have sufficient electrolyte to cover the plates plus $\frac{1}{4}$ of an inch. Use only distilled or deionized water.
- Connect 120VAC to the covered receptacle on right side of pedestal assembly.
- Do a "dirty connection" check by using a sensitive DC voltmeter to measure the voltage drop between the battery posts at the ends of each jumper cable of the battery pack. If there are more than 4 millivolts drop from post to post, then disconnect the 120VAC from the receptacle and clean and reconnect the cable connections.
- Reconnect the 120VAC to the pedestal receptacle.

After batteries become fully charged (specific gravity 1.25 +/- .010 with a temperature compensated hydrometer), replace those which were rejected with good, fully charged batteries of the SAME brand and size as the rest of the pack.



IMPORTANT NOTES:

- Electrolyte level in the batteries should be checked before and after each charging in addition to regular, periodic examinations. Replenish electrolyte with either distilled or de-ionized water up to the bottom of the 'fill' vent tube, but no higher. Note: adding water just before taking hydrometer readings will yield erroneous readings.
- A battery having a lesser or greater charge level than the pack must not be connected to that pack. To do so risks battery explosion.
- Any sparking as the cables are being connected indicates uneven charging and may ignite an explosion.
- Charging to specific gravity readings above 1.265 will cause damage to the battery plates.
- For proper charging and electrolyte destratification, allow charging, from the 120V line, to continue until the charging voltage drops back from 14.1V+/- to 13.2V+/- . Note that at the start of charging, the charging voltage may be 13.2V, more or less, but will be rising rather than dropping back.
- Batteries allowed to be abused by being discharged below the "required blank state" level will require considerable time on the charger just to bring them up to a condition in which they can begin to accept a charge. Under certain low temperature conditions, excessive discharging can permanently damage the batteries due to freezing. Charging of damaged batteries can cause a potentially dangerous condition for personnel and equipment. Therefore, maintain a good charge level in the batteries during cold weather because lead/acid batteries can freeze and can be ruined if they are sufficiently discharged.
- Interruptions of the 120VAC supply line may cause the charger to reset which will lengthen the charging time. It may be necessary to disconnect both AC and DC from the charger, put a load on the batteries to burn off any surface charge and then reconnect the batteries and 120VAC to restart the charger.
- 12GA 120VAC inlet cords (min.) should be used with the 75A chargers.
- 120VAC generators used with these chargers should be rated at 5KW, heavy duty (min.).



4.5 SEASONAL STORAGE

Fully charge and fully deplete batteries while in storage. If the sign is in storage for longer than a month, take the following measures to insure optimal battery and sign performance:

1. Blank the sign display.
2. On a full battery charge, leave the sign unused for 30 days.
3. Use the AC adapter to charge the batteries for 2 days.
4. Repeat the 30/2 cycle for the duration of storage.

Letting the batteries die for an extended period of time may prevent them from holding a charge again. In a blanked state, the batteries may last longer than 30 days before running out of a charge, but we schedule the charging to coincide with regular monthly maintenance for user convenience.

4.6 Mast

When pulling a sign in from the field for either storage or maintenance the user may notice the mast is rusted and/or dry from being exposed to weather.

- DO NOT use liquid lubrication on the mast to assist in the lowering process.
- Amsig recommends a **spray on industrial graphite dry lubricant** for mast lubrication.
- If hydraulic operation is not possible for some reason, call our Service Department immediately.



5.0 Wiring Diagrams

The wiring diagrams for the 33x trailers are identical, except for the quantity of display panels, batteries and/or solar panels. The wiring diagrams for the T331, T332 and T333 are included in this section. Drawings are subject to change. The remaining wiring diagrams for these series of trailers can be obtained from American Signal Company by contacting the Service Department or the appropriate sales representative. The drawing numbers for the system wiring diagrams are shown below.

Model #	Wiring Diagram Drawing #
T331E	AMS30065208-WIR
T331	AMS30065211-WIR*
T332E	AMS30065248-WIR
T332	AMS30065251-WIR*
T333E	AMS30065268-WIR
T333	AMS30065271-WIR*

* = included in this Section



AMERICAN SIGNAL COMPANY
 2755 Bankers Industrial Dr.
 Atlanta, GA 30360
 Phone: 770-448-6650
 Fax: 770-448-8970

5.1 Model T331 System Wiring

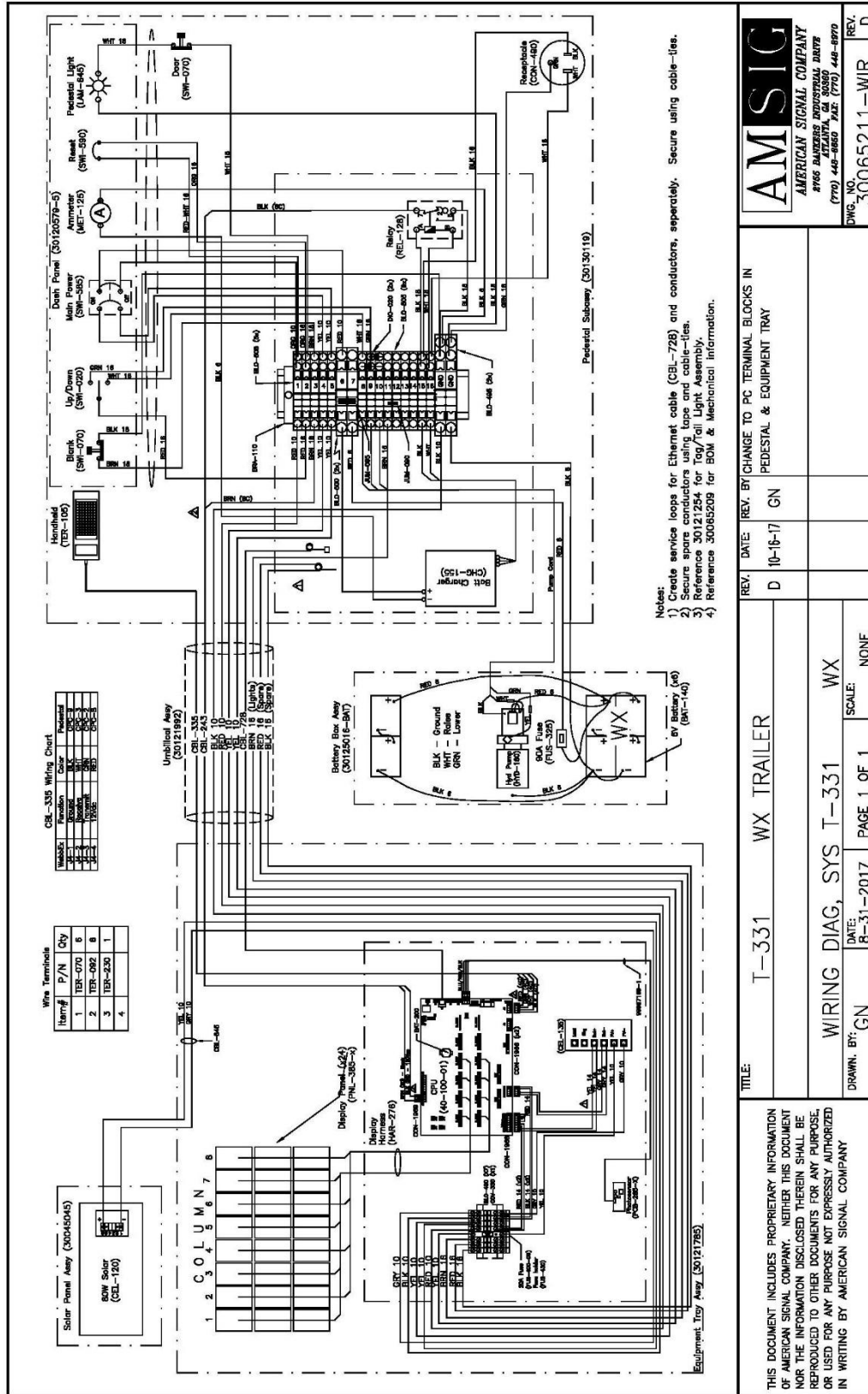

AM SIG
 AMERICAN SIGNAL COMPANY
 2755 BANKERS INDUSTRIAL DR.
 ATLANTA, GA 30360
 (770) 448-6650 FAX: (770) 448-8970
 DWG. NO. 30065211-WIR REV. D

REV. DATE	REV. BY	CHANGE TO
D 10-16-17	GN	PEDESTAL & EQUIPMENT TRAY

TITLE:	T-331	WX TRAILER
--------	-------	------------

WIRING DIAG, SYS T-331	WX
------------------------	----

DRAWN BY:	GN	DATE:	B-31-2017	PAGE 1 OF 1	SCALE:	NONE
-----------	----	-------	-----------	-------------	--------	------

THIS DOCUMENT INCLUDES PROPRIETARY INFORMATION OF AMERICAN SIGNAL COMPANY. NEITHER THIS DOCUMENT NOR THE INFORMATION DISCLOSED THEREIN SHALL BE REPRODUCED TO OTHER DOCUMENTS FOR ANY PURPOSE, OR USED FOR ANY PURPOSE NOT EXPRESSLY AUTHORIZED IN WRITING BY AMERICAN SIGNAL COMPANY.



AMERICAN SIGNAL COMPANY
 2755 Bankers Industrial Dr.
 Atlanta, GA 30360
 Phone: 770-448-6650
 Fax: 770-448-8970

5.3 Model T333 System Wiring

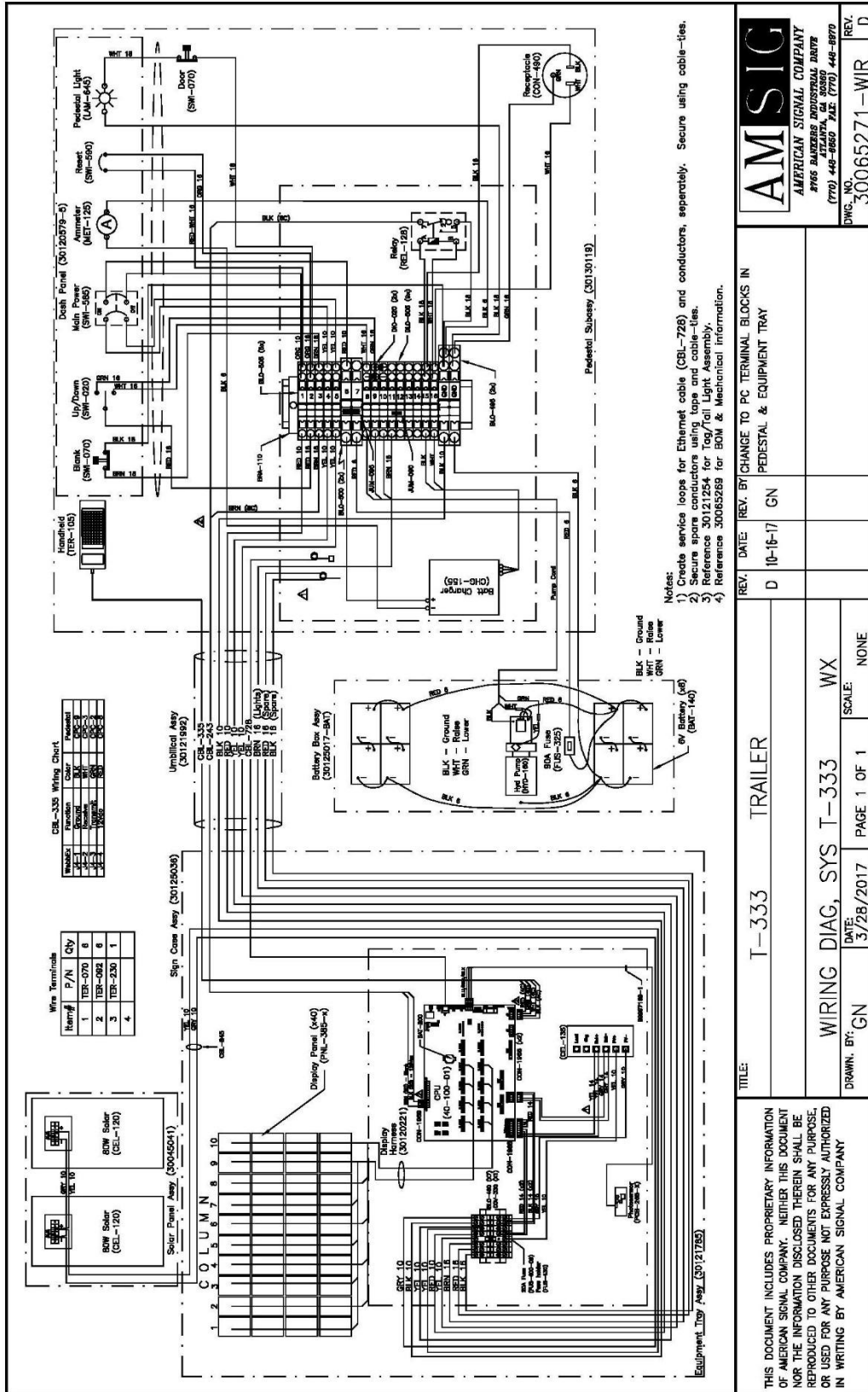



6.0 Mechanical Drawings

The mechanical dimensions for the T33x trailers are identical to each other. Also, the mechanical dimensions for the three T33xE trailers are identical to each other, except for the quantity of solarpanels. The sales drawings for the T33x and the T33xE can be obtained from Amsig by contacting the Service Department or the appropriate sales representative. The drawing numbers for the sales drawings are shown below:

Model #	Drawing #
T331E	AMS30065208
T331	AMS30065211
T332E	AMS30065248
T332	AMS30065251
T333E	AMS30065268
T333	AMS30065271



7.0 Trouble Shooting

ISSUE	POSSIBLE CAUSE(S)	SOLUTION
LED panel does not display	faulty LED panel; faulty panel cable harness	Switch panel with a known good panel. If suspected faulty panel still does not display then panel needs to be replaced. If known good panel does not display then cable harness likely needs to be replaced
Terminal displays "Low Voltage Lockout"	system battery voltage is too low to power sign (below 11.2 V)	Apply AC power to trailer until onboard ammeter reads 0 (typically 2-3 days, depending on the size of your battery bank).
Sign enters "Low Voltage Lockout" regularly	poor solar exposure; expired batteries	Move unit to area with more solar exposure to solar panels. Monitor "Charge Amps" field in "Status" screen. Use a hydrometer to test each cell of each battery (lead acid type batteries only).
Display remains too bright/dim after change in ambient lighting	"Brightness" setting is set to "Manual" instead of "Auto"	Change "Brightness" mode in "Admin" menu from "Manual" to "Automatic".
LED's or characters remain on, or display "junk" characters	static on cable harness; faulty LED panel	Reboot unit's main power and observe display. If problem persists, switch panel with a known good panel and observe display.
Can no longer connect to sign remotely via cell modem	cell carrier error; poor cellular signal; faulty modem; faulty CPU	Confirm account validity with carrier. Ping IP address. Enter modem interface page to view cell signal strength.
"Failed to Load" error message over Web Control	incompatible browser; outdated firmware	Use Google Chrome or Mozilla Firefox for Web Control. Contact our Service Department for the latest version of our Webb Express firmware



AMERICAN SIGNAL COMPANY

2755 Bankers Industrial Dr.

Atlanta, GA 30360

Phone: 770-448-6650

Fax: 770-448-8970

8.0 Service Contact

Online Support: <http://amsig.com/support/>, where you will find manuals, quick guides, and other resources. You can also submit an inquiry through our website at <http://amsig.com/contact-us/>.

Email: service@amsig.com

Phone: 770.448.6650 (use extension 3 to reach the Service Department)

Fax: 770.448.8970

Write: American Signal Company – Service Department

2755 Bankers Industrial Drive

Atlanta, GA 30360