

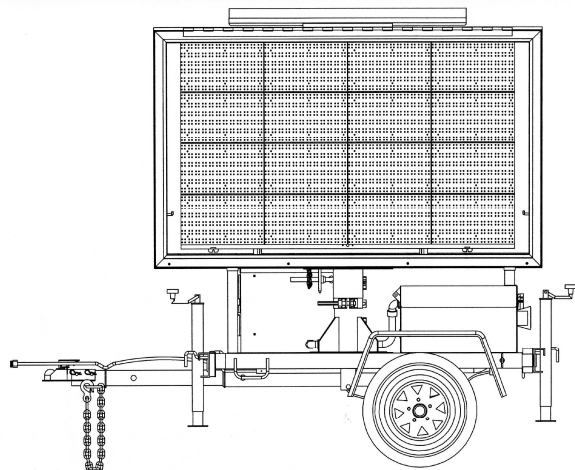

AMERICAN SIGNAL COMPANY
2755 Bankers Industrial Dr.
Atlanta, GA 30360
Phone: 770-448-6650
Fax: 770-448-8970

Models 232/432/465 Service and Maintenance Manual

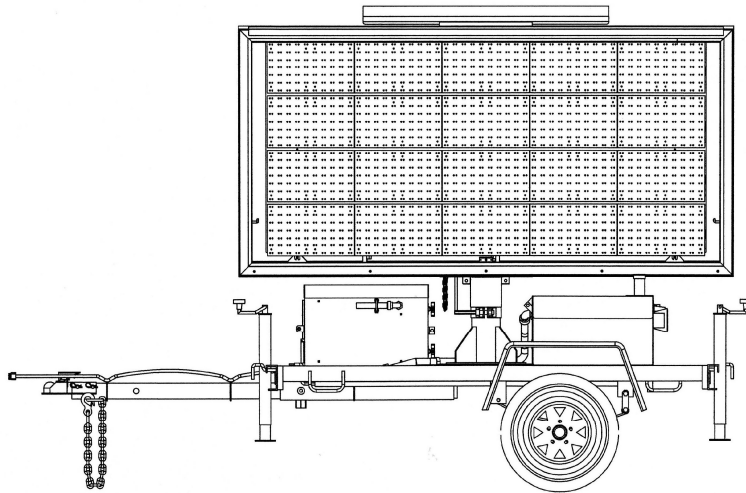
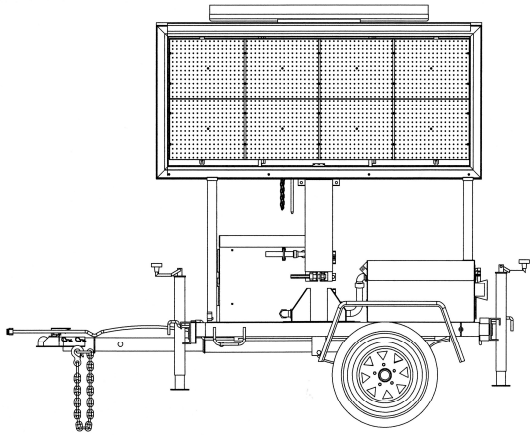

Document #: MAN0000023-1
Revision: E
Date: 3-30-2018



AMERICAN SIGNAL COMPANY

2755 Bankers Industrial Dr.

Atlanta, GA 30360

Phone: 770-448-6650

Fax: 770-448-8970

AMERICAN SIGNAL COMPANY
Amsig® Limited Warranty

Limited Warranty. Amsig® warrants all portable changeable message signs against manufacturing defects in materials and workmanship for one year from the date of shipment from Amsig®'s factory. Within this period Amsig® will repair or replace equipment returned to the factory prepaid, without charge for parts and labor. After repair or replacement, Amsig® will ship the equipment back to the Buyer by the same mode or type of delivery used by the Buyer to send the equipment to Amsig® (overnight courier, same class of mail or UPS delivery, freight line, etc.).

This limited warranty does not cover (a) damage or failure caused by or attributable to acts of God, abuse, misuse, improper or abnormal usage, faulty installation, improper maintenance, lightning or other incidents of excessive voltage; (b) any repairs other than those provided by an Amsig® authorized service facility; or (c) transportation costs other than as provided above.

Certain components of the equipment are covered by warranties from manufacturers other than Amsig®. Copies of those warranties will be delivered to the Buyer along with the equipment. Amsig® has no liability for and does not provide warranty service for these items, which include engine, battery or batteries, battery charger, hydraulic pump system, tires, wheels, axles, brakes, and trailer hitch (if any). The Buyer should consult the applicable manufacturer for a specific warranty regarding a specific component. Amsig®'s limited warranty does not cover any damages to parts otherwise covered by Amsig®'s limited warranty if and to the extent that such damages are caused by or result from a defective or malfunctioning item warranted by another manufacturer.

Amsig®'s limited warranty obligation shall be automatically suspended upon the Buyer's failure to pay any obligation owed to Amsig® according to the terms agreed upon between them (whether pursuant to this Quotation or any other agreement between them). Such suspension shall continue until the Buyer has paid such obligation in full. Notwithstanding the foregoing, Amsig® shall honor its limited warranty obligation for any equipment that has been sold by the Buyer, unless the owner of the equipment is in default under any obligation to pay the Buyer for such equipment.

As owner's sole and exclusive remedy under these warranties, Amsig® shall, in its sole discretion either (i) provide services to repair a nonconformity with these limited warranties, or (ii) replace the nonconforming component of its product. THE FOREGOING IS OWNER'S SOLE AND EXCLUSIVE REMEDY FOR BREACH OF THESE WARRANTIES.

EXCEPT AS PROVIDED ABOVE, Amsig® MAKES NO EXPRESS WARRANTIES. FURTHER, Amsig® MAKES NO WARRANTY OF MERCHANTABILITY AND NO WARRANTY OF FITNESS FOR ANY PARTICULAR PURPOSES WHATSOEVER WITH RESPECT TO THE EQUIPMENT BEING SOLD.

©Copyright 1995-2018, American Signal Company, Inc. All Rights Reserved. No portion of this document may be reproduced in any form without express written permission from American Signal Company



Table of Contents

I. Revision Information.....	5
1.0 Introduction.....	6
1.1 Standard Features.....	7
1.2 Available Options.....	8
2.9.1 Solar Option.....	8
2.9.2 Radar Options.....	8
2.9.3 Communication Options.....	8
2.9.4 Hitch Options.....	8
2.9.5 Tire Options.....	8
2.9.6 Security Options.....	8
2.0 Trailer Transport and Deployment.....	9
2.1 Charge the Batteries.....	9
2.2 Tow the Trailer.....	10
2.3 Level Trailer - Operating Position.....	12
2.4 Raise & Lower Sign Case (Hydraulically).....	13
2.4.1 Raise Sign Case.....	13
2.4.2 Lower Sign Case:.....	14
2.5 Raise & Lower Sign Case (Manually).....	15
2.5.1 Manually Raise Sign Case.....	15
2.5.2 Manually Lower Sign Case.....	15
2.6 Install/Remove/Retract Tongue Assembly or Remove Hitch.....	16
2.6.1 Install the Tongue Assembly.....	16
2.6.2 Remove the Tongue Assembly.....	16
2.6.3 Remove the Hitch.....	16
2.6.4 Retract and Stow the Tongue Assembly.....	17
3.0 Advantage Series Components & Options.....	18
3.1 Sign Case Assembly.....	18
3.2 Battery Box.....	21
3.3 Cylinder.....	23
3.4 Solar Panel Assembly.....	23



AMERICAN SIGNAL COMPANY
2755 Bankers Industrial Dr.
Atlanta, GA 30360
Phone: 770-448-6650
Fax: 770-448-8970

3.5 Pedestal Assembly	24
3.6 Tires & Axle	26
3.7 Tongue Assembly	26
3.8 Leveling Jacks	27
3.10 Spare Parts List.....	28
4.0 Advantage System Maintenance	29
4.1 Sign Case Assembly Maintenance	29
4.2 Hydraulic Pump Maintenance	32
4.3 Solar Panels.....	33
4.4 Battery Maintenance	33
4.5 SEASONAL STORAGE	36
4.6 Mast	36
5.0 Wiring Diagrams.....	36
5.1 Model 232 Advantage.....	37
5.2 Model 432 Advantage.....	38
5.3 Model 465 Advantage.....	39
6.0 Mechanical Drawings	40
7.0 Trouble Shooting.....	41
8.0 Service Contact	42



AMERICAN SIGNAL COMPANY
2755 Bankers Industrial Dr.
Atlanta, GA 30360
Phone: 770-448-6650
Fax: 770-448-8970

I. Revision Information

Rev.	Date	Author	Reason	Page
A	7-22-04	Price R. Potter	Initial Release	-
B	11-1-04	Price R. Potter	Add ***CAUTION*** notes to Sign Case Assembly Maintenance	23
			Revise wiring diagrams for Model 232 Adv (30062800-WIR, Rev. D), 432 Adv (30064700-WIR, Rev. F) & 465 Adv (30064600-WIR, Rev. F)	27, 28, 29
C	11-23-04	Price R. Potter	Revise wiring diagrams for Model 232 Adv (30062800-WIR, Rev. E) & 432 Adv (30064700-WIR, Rev. G)	27, 28
D	2-10-06	Price R. Potter	Update Sections 1.1, 1.2 and 1.3; Revise wiring diagram for 232 (30062800-WIR), 432 (30064700-WIR) and 465 (30064600-WIR); Revise mechanical drawing for 232 (30062800), 432 (30064700) and 465 (30064600)	7-12; 30-32; 34-36
E	3-20-18	Kevin Sampler	Complete Update	All



1.0 Introduction

The information contained in this manual describes the Advantage Series Portable Changeable Message Sign (PCMS). The American Signal model numbers for these Advantage Series of PCMS products are:

- T232, S232
- T432, S432
- T465, S465

The differences between the model designators are:

- T – Trailer-mounted with standard trailer length and power configuration
- S – Stationary, not mounted on a trailer

All of these models have full matrix displays and mount on the Advantage or Advantage-S Trailer system. The major differences between these products are the size of the sign case and the configuration of the LED display panels, which are illustrated in the following chart:

Advantage Model #	Sign Case size	Trailer Frame size	LED Configuration		
			Rows	Columns	Pixel
232	3' High x 6' Wide	63" wide X 103" long	28	72	1 LED/Pixel
432	4' High x 8' Wide	72" wide X 134" long	28	50	2 LEDs/Pixel
465	4' High x 6' Wide	63" wide X 103" long	28	48	4 LEDs/Pixel

A more complete list of the standard features and available options for each model is contained in the next subsections.

Detailed information on the operation and programming of the PCMS software is contained in MAN00000095 Software Operations Manual, 33x/x32



AMERICAN SIGNAL COMPANY
2755 Bankers Industrial Dr.
Atlanta, GA 30360
Phone: 770-448-6650
Fax: 770-448-8970

1.1 Standard Features

The following is a list of the standard features on all Advantage Series models

Highway Orange/Flat Black Color
Full Matrix PCMS
6V Batteries (4x)
75A Charger
80W Solar Panel (1x)
Bolt-On Mast
2000 lb. Axle w/ 13" Tires (2x) load rated at 1360 lbs. each
Low-Profile NEMA 4 Style Pedestal Enclosure
Hand-held Terminal
2" Removable Pinned-On Ball Hitch
Removable Tongue
Hydraulic Pump & Cylinder (for raising/lowering Sign)
Leveling Jacks (4x)

NOTE: All of the above information (standard battery and solar as well as standard features) is subject to change at the discretion of American Signal Company.



AMERICAN SIGNAL COMPANY
2755 Bankers Industrial Dr.
Atlanta, GA 30360
Phone: 770-448-6650
Fax: 770-448-8970

1.2 Available Options

The following is a brief description of the options available with the Advantage Trailers. More complete and detailed information for some options is contained in other literature.

2.9.1 Solar Option

The AimStar® solar panel assembly contains two 80W or 130W solar panels that can be oriented and angled independent of the sign case. By pointing the solar panels more toward the path of the sun, they can generate additional power during available daylight hours for recharging of the batteries. The AimStar® option replaces the existing flat solar panel assembly.

2.9.2 Radar Options

The optional radar unit is a custom directional radar unit (DRU) that can measure oncoming traffic data (speed). This speed can also be dynamically displayed on the PCMS to inform motorist of their rate of travel. The radar is mounted under the sign case assembly and can be provided in a fixed or swivel configuration.

2.9.3 Communication Options

The Advantage Series PCMS can be remotely controlled and operated through a cell phone/modem connection from a personal computer. Digital and analog options are available depending on the location and the equipment is mounted in the sign case assembly.

2.9.4 Hitch Options

The standard 2" ball hitch can be replaced or used in conjunction with by a 2.5" or 3.0" Lunette eye. An adjustable bolt-on mounting configuration can also be provided.

2.9.5 Tire Options

A spare tire and mount can be bolted to the Trailer. An extra tongue-mounted Jack can also be added to the trailer.

2.9.6 Security Options

A wheel lock bar & padlock can be provided to give added security to the PCMS. By sliding the wheel lock bar through both tire rims and padlocked in place, unauthorized movement of the trailer and/or removal of the tires is prevented. During travel, the wheel lock bar is stored and secured inside the tongue tube under the trailer. Another security option is the locking lug nuts that stop theft of the tires.



AMERICAN SIGNAL COMPANY
2755 Bankers Industrial Dr.
Atlanta, GA 30360
Phone: 770-448-6650
Fax: 770-448-8970

2.0 Trailer Transport and Deployment

2.1 Charge the Batteries

Before deployment, it is necessary to ensure that the battery electrolyte level is properly maintained and that the voltage level is above 12VDC. If battery voltage is below 11.2VDC the PCMS display will not operate. It may be necessary to recharge the batteries with 120VAC (from a landline or generator) before operating the PCMS. Fully charged batteries will be 13.2-13.6VDC

The solar-assisted battery power supply system furnished with the Advantage Series PCMS includes multiple deep-cycle 6V batteries which are uniquely able to withstand the deep discharges that occur periodically during normal operation. The system has been designed to provide sign operation over all of the usable state of charge level of the batteries.

Depending upon several factors (i.e. length & duration of message displayed, the brightness level, the number of solar panels, the amount of available sunlight, the number of batteries, the age of the batteries and the ambient temperature), voltage level of the battery pack can eventually drop below 11.2VDC, and the PCMS display will stop operating. At that time (or sooner, if desired), it will be necessary to recharge the batteries with 120VAC (from a landline or generator). An abbreviated summary of steps to charge the batteries with the provided 75A charger is shown below (for detailed battery maintenance instructions see Section 4.4):

- Bring 120VAC to trailer and plug into covered receptacle on right side of pedestal assembly.
- Apply AC power to trailer until onboard ammeter reads 0 (typically 1-2-3 days, depending on the size of your battery bank).
- When batteries are fully charged, unplug 120VAC power source from pedestal. Batteries are fully charged when the specific gravity with a temperature compensated hydrometer is 1.25 +.010.

In dealing with batteries, great care should be taken during their handling, charging, and maintenance. More detailed information on aspects of, and precautions for, charging batteries is provided in the Maintenance section.



2.2 Tow the Trailer

Prior to actually towing the trailer, additional steps must be taken to ensure that the unit is ready and safe for travel:

- Crank up and rotate horizontal all jacks
- Lower the sign case assembly
- Engage the sign case brake

Raise and stow the rear leveling jacks (this makes it easier to engage/disengage the towing tongue to the hitch). In order to keep the horizontal jacks within the footprint of the trailer, rotate each jack with the foot facing toward the fender and that the crank handle is collapsed onto the jack. Ensure that the lock pin snaps into position when the jack is horizontal.



Remove the locking pin from the locking lever on the trailer hitch.
Lift the locking lever on the trailer hitch



Position the hitch receiver over the towing vehicle ball hitch and lower the hitch to firmly seat around the ball.

Push the locking lever down to engage the lock.

Insert the locking pin through the hole in the lever to prevent accidental unlocking.





AMERICAN SIGNAL COMPANY
2755 Bankers Industrial Dr.
Atlanta, GA 30360
Phone: 770-448-6650
Fax: 770-448-8970

Attach the safety chains to the appropriate attach points on the towing vehicle



Attach the electrical connector from the tongue assembly to the electrical connector on the towing vehicle (for tag, trailer, and brake lights).





AMERICAN SIGNAL COMPANY
2755 Bankers Industrial Dr.
Atlanta, GA 30360
Phone: 770-448-6650
Fax: 770-448-8970

2.3 Level Trailer - Operating Position

To level the trailer, pull the spring-loaded lock pin and rotate jacks to the down position. Crank the handle at the top of each jack to extend the support leg and foot down to the ground/pavement. Adjust extension of four jacks as needed to level the trailer.

The rear jacks on the Advantage 232 and Advantage 465 trailers are attached to extendable outriggers for added stability in the field. To operate the outriggers pull the locking pin, pull the outrigger out and reinsert the pin through the frame.

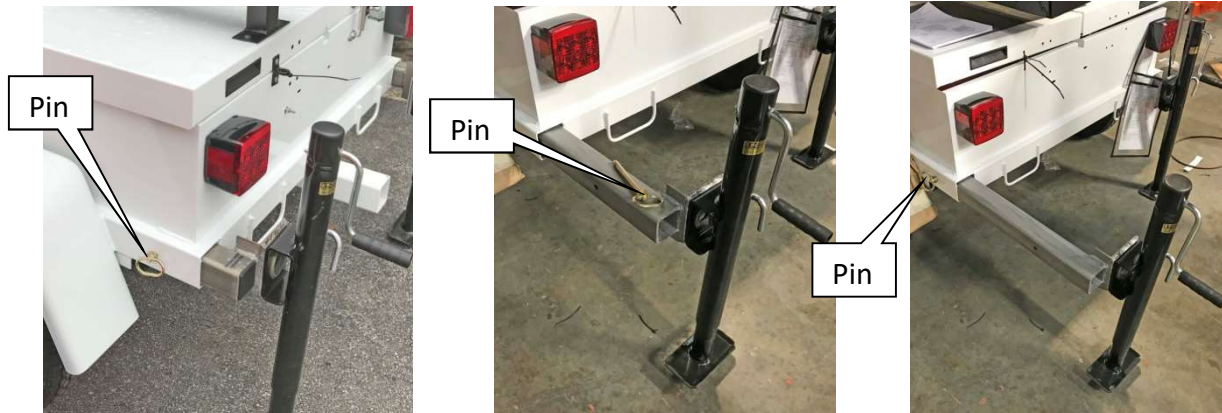

The jacks on the Advantage 432 trailer are mounted directly to the longer frame.





2.4 Raise & Lower Sign Case (Hydraulically)

2.4.1 Raise Sign Case

Under normal operating conditions, the sign case is raised and lowered via the hydraulic pump and cylinder mechanism. To raise the sign case, perform the following steps:

Loosen the both brake band rods on the mast assembly with the provided closed-end ratchet (located in the bottom front of the pedestal assembly). Failure to loosen both brake bands before attempting to raise the PCMS may cause damage to the unit.

Toggle the “Up-Down” switch on the dash panel in pedestal assembly to the upper position. **DO NOT TAKE THE RODS ALL THE WAY OUT.**

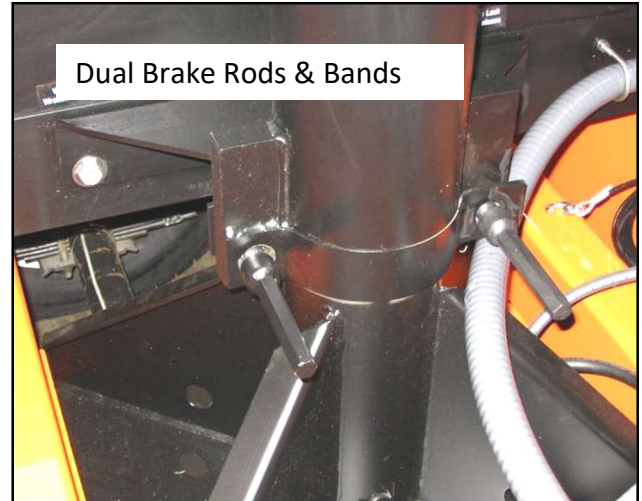

The operator can place a hand on the sign case as it is raised to avoid unwanted rotational movement due to wind or trailer tilt.

When the cylinder has reached its maximum extension, the sign case will stop (with an audible thump). Slide the safety pin, chained to the outer mast, through the two holes in the inner mast. It will be necessary to stand on the trailer frame to reach the safety pin and inner mast holes. The safety pin will stop the sign case from failing in the event of cylinder malfunction or loss of hydraulic pressure.

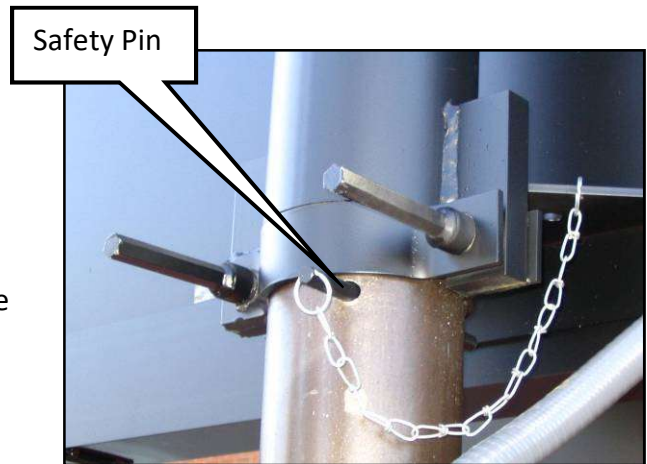

- Once the safety pin is in place, the sign case should be lowered to rest on the pin. The sign case is free to rotate more than 360 degrees and can now be aimed in the desired direction by utilizing the sight tube mounted to the bottom of the sign case.
- After the PCMS is oriented correctly, use the ratchet to tighten both brake band rods thereby preventing the sign case from rotating.



AMERICAN SIGNAL COMPANY
2755 Bankers Industrial Dr.
Atlanta, GA 30360
Phone: 770-448-6650
Fax: 770-448-8970

2.4.2 Lower Sign Case:

- Use the ratchet to loosen the both brake band rods.
- Toggle the “Up-Down” switch on the dash panel to the upper position to lift the sign case off of the safety pin.
- Remove safety pin from inner mast and replace in hole in outer mast bracket.
- Rotate the PCMS so as to orientate the sign face to the side of the trailer and away from the pedestal assembly and above the cradle platforms on the trailer deck.
- Toggle the “Up-Down” switch on the dash panel to the lower position to begin lowering the sign case.

It may be necessary to place a hand on the sign case as it is lowered to avoid unwanted rotational movement due to wind or trailer tilt. It is important that the sign case be guided downward so as to not be lowered onto the trailer pedestal assembly potentially causing damage or injury. Continue guiding the sign case down until it rests on the rear cradle rubber strips on the trailer deck (travel position).

After the PCMS is oriented correctly on the battery box, use the ratchet to tighten both brake band rods, thereby preventing the sign case from being jarred out of travel position. The sign case must be in the cradle and both brake band rods must be tightened prior to towing the trailer.





2.5 Raise & Lower Sign Case (Manually)

In the event that the hydraulic pump does not activate through the switch it can be manually operated to raise and lower the sign case. To manually raise or lower the sign, follow all of the steps involved in hydraulically moving it up and down, plus do the following:

2.5.1 Manually Raise Sign Case

- Open the split lid on the battery box (the side that does not have the sign case cradle)
- Insert the pump handle (mounted in battery box next to pump) into the manifold on the side of the Pump.
- Push the pump handle back & forth to force hydraulic fluid into the cylinder, thereby raising the sign.



2.5.2 Manually Lower Sign Case

- Open the split lid on the battery box (the side that does not have the sign case cradle)
- Place notch in end of pump handle over T-handle valve on top of pump.
- Rotate the pump handle in small increments to release hydraulic pressure in the cylinder and lower the sign.



AMERICAN SIGNAL COMPANY
2755 Bankers Industrial Dr.
Atlanta, GA 30360
Phone: 770-448-6650
Fax: 770-448-8970

2.6 Install/Remove/Retract Tongue Assembly or Remove Hitch

2.6.1 Install the Tongue Assembly

In order to reduce the space needed to transport the trailers, the tongue assembly may be shipped uninstalled. To install the tongue assembly:

- Remove the 1" diameter pin from the frame.
- Align rear of tongue assembly with sleeve in front of trailer and insert tongue until hole in tongue lines up with hole in rear sleeve.
- Reinsert 1" diameter pin through mating holes.
- Reinstall the safety clip in the bottom of the pin
- Connect mating trailer light connectors on tongue and trailer together.

2.6.2 Remove the Tongue Assembly

The tongue assembly can also be removed to inhibit theft of the trailer. To remove the tongue assembly:

- Remove 1" diameter pin from the trailer frame.
- Unplug mating trailer light connectors on tongue and trailer.
- Pull tongue assembly forward until tongue comes completely out of the sleeve.
- Reinsert 1" diameter pin through hole in the trailer frame
- Reinstall the safety clip in the bottom of the pin



2.6.3 Remove the Hitch

Instead of removing the entire tongue assembly, the hitch can be removed individually to inhibit theft of the trailer. Due to size and weight considerations, removal of the hitch is sometimes a more appropriate method of preventing theft. To remove the hitch:

- Remove cotter pins (2x) from hitch pins (2x).
- Slide hitch pins out of hitch.
- Remove the hitch from tongue tube.



AMERICAN SIGNAL COMPANY
2755 Bankers Industrial Dr.
Atlanta, GA 30360
Phone: 770-448-6650
Fax: 770-448-8970

2.6.4 Retract and Stow the Tongue Assembly

The tongue assembly can be retracted and stowed to reduce the area needed to store the trailer. To stow the tongue assembly:

- Unlock padlock through pin located in center tube of trailer frame.
- Remove pin from hole in center tube.
- Push tongue assembly back until forward hole in tongue lines up with hole in center tube of trailer frame.
- Reinsert pin thorough mating holes and lock padlock through hole in pin





3.0 Advantage Series Components & Options

The Advantage Series standard components and their functions are briefly described in this section. References to and pictures showing specific brands of equipment are included for discussion purposes only. All brands, equipment and designs are subject to change at any time without notice. Wiring diagrams, mechanical drawings, part numbers and technical specifications are contained in other sections. (NOTE: P/Ns with revisions are denoted with an “-x” suffix. Call factory for applicable (or current) revision level.)

3.1 Sign Case Assembly

The sign case assembly provides the housing for many of the major PCMS components, including the display panels, central processing unit (CPU), solar booster/regulator and anti-glare treated lens. See the Trailer Operation section for information on accessing the internal components of the sign case.

Display Panel

The display panels contain the LEDs and are mounted to the lens (232) or to a hinged pan (432 & 465) behind the lens. The LEDs on all of these display panels are amber in color. The display panels are connected to the CPU in columns with two Mass Termination Assembly (MTA) connectors (232) or one MTA connector (432 & 465) providing power and data to each panel.

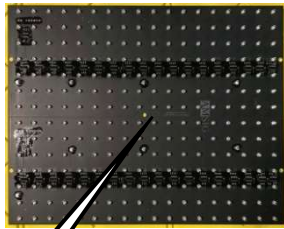

1 232 Display Panel

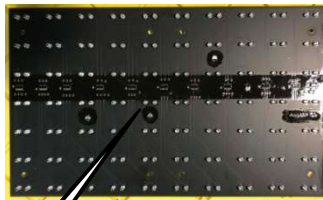

2 432 Display Panel

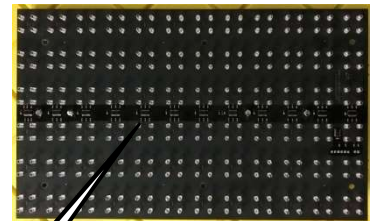

3 465 Display Panel

#	Part Description	Part Number
1	Display Panel, 18x14 1 LED/Pixel 30 deg	PNL00000318-x
2	Display Panel, GP-432 2 LED/Pixel 23 deg	PNL00000307-x
3	Display Panel, 12x6 4 LED/Pixel 23 deg	PNL00000342-x



AMERICAN SIGNAL COMPANY
2755 Bankers Industrial Dr.
Atlanta, GA 30360
Phone: 770-448-6650
Fax: 770-448-8970

Lens

The Lens is a UV-protected clear polycarbonate with matte finish to provide contrast, to reduce glare, and to protect the LEDs.



#	Part Description	Part Number
4a	Polycarb lens (232)	PLA-335-1
4b	Polycarb lens (432)	AMS30060157
4c	Polycarb lens (465)	PLA-310-1



Equipment Tray

232

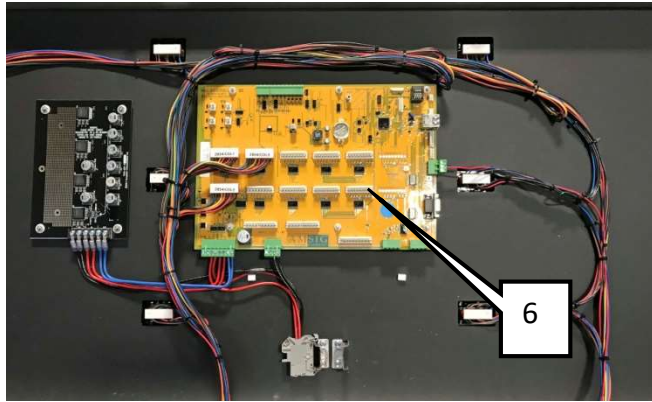

432 & 465

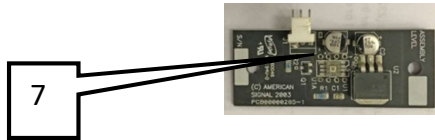
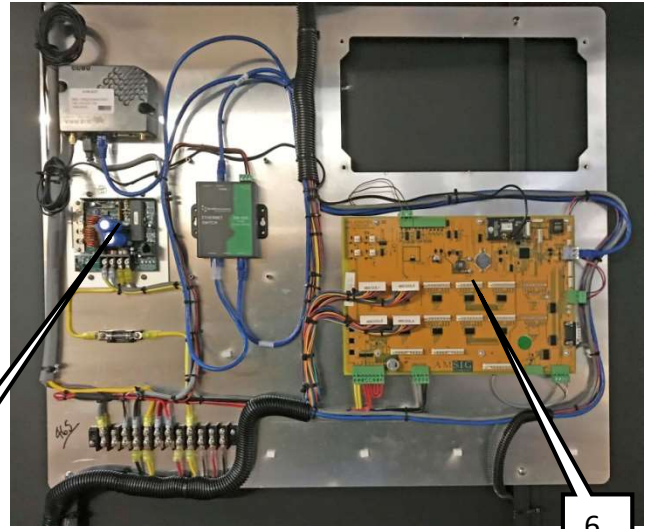

7

8

6

Central Processing Unit

The CPU is the “brain” of the PCMS and is located on the back panel inside the sign case. The CPU provides power & data to the display panels, monitors solar and battery charging, and is connected to the hand held terminal through the umbilical.

Photosensor Board

The Photosensor Board is mounted on the sign case hinged pan. The photosensor is the device that measures the amount of ambient light that is present at the PCMS. This value is correlated to a brightness level in the DIM table and allows control of the LEDs to be brighter or dimmer as current conditions require.

#	Part Description	Part Number
6	CPU	40-00100-01
7	Photosensor board	PCB-265-x
7A	Photosensor light harness (NOT shown)	HAR625
8	Solar booster	CEL-135



3.2 Battery Box

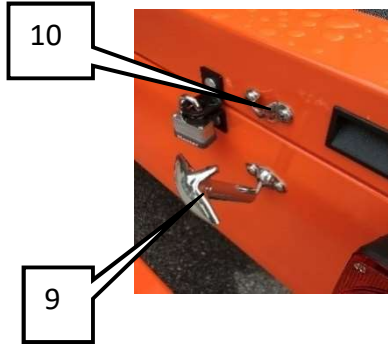
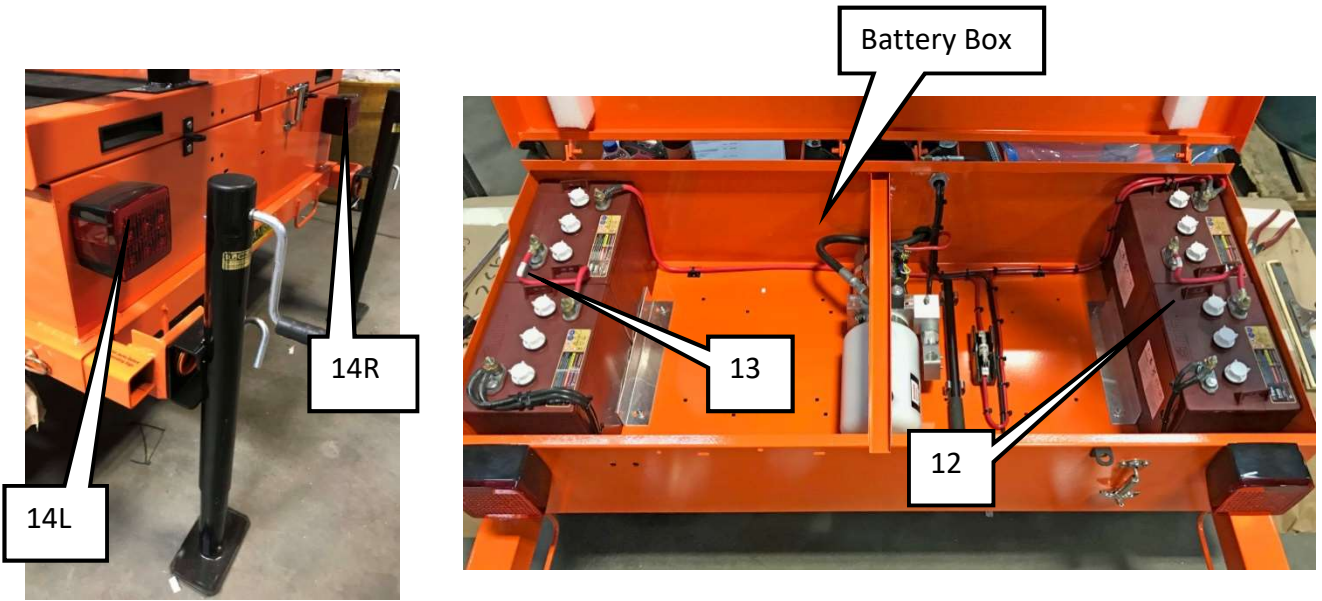

Batteries

The Ad Series trailers are populated with 6V batteries wired parallel/series to provide 12VDC to the sign.

#	Part Description	Part Number
9	Latch	LAT-70
10	Hook	LAT-80
12	Battery, 6V Deep Cycle 215 Amp-Hrs	BAT-140
13	Battery cables (various lengths and colors)	Call Amsig Service
14L	Lamp, tail left side	LAM23
14R	Lamp, tail right side	LAM33



The hydraulic pump and cylinder provide the lifting mechanism to raise (for deployment) and lower (for travel and storage) the sign case.

Hydraulic Pump

The hydraulic pump is a 12VDC pump and hydraulic reservoir that provides the hydraulic pressure to the cylinder to raise and lower the sign case assembly. The pump is mounted in the battery box and the “Up-Down” toggle switch that controls it is located in the pedestal assembly dash panel. In the event that the hydraulic pump malfunctions, it can be manually operated to raise and lower the sign case.

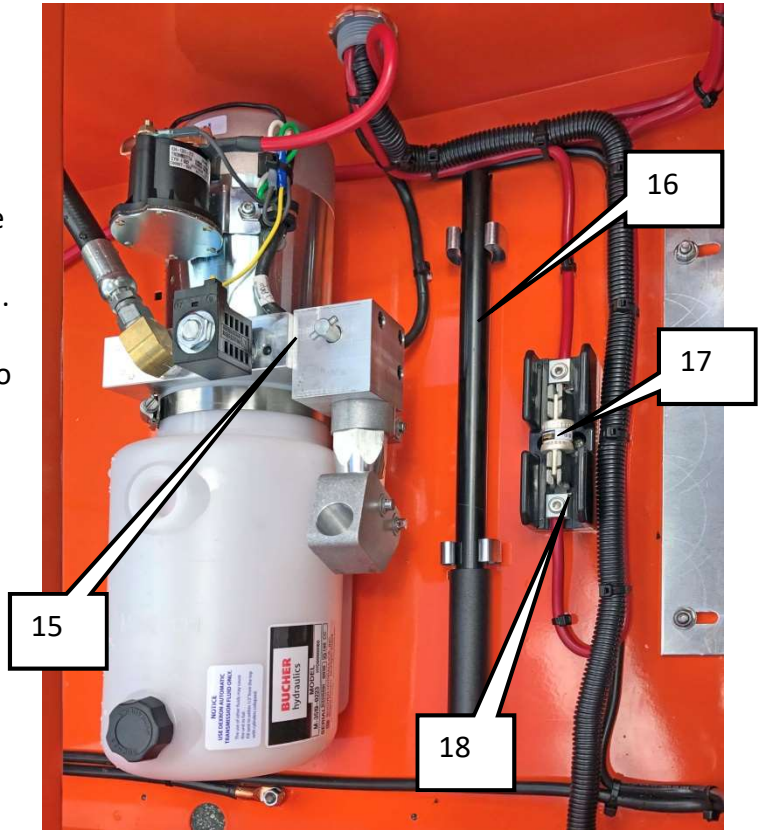

#	Part Description	Part Number
15	Hydraulic pump	HYD-160
16	Manual pump handle	HYD-171
17	Fuse	FUS-325
18	Fuse holder	FUS-315
	Hydraulic fluid – available at local auto parts stores	Any Automatic Transmission Fluid (ATF) can be used



3.3 Cylinder

The lifting cylinder is located inside of the mast assembly and is connected to the pump by a hydraulic hose and fittings assembly. As the cylinder extends and retracts, the sign case is raised and lowered.

3.4 Solar Panel Assembly

The solar panels convert sunlight into electrical power (12VDC) to maintain the charge state of the batteries. This re-charging of the batteries allows the PCMS to operate over a longer period of time before requiring landline (or generator) 120V charging. See Specifications section for more information on the solar panel.

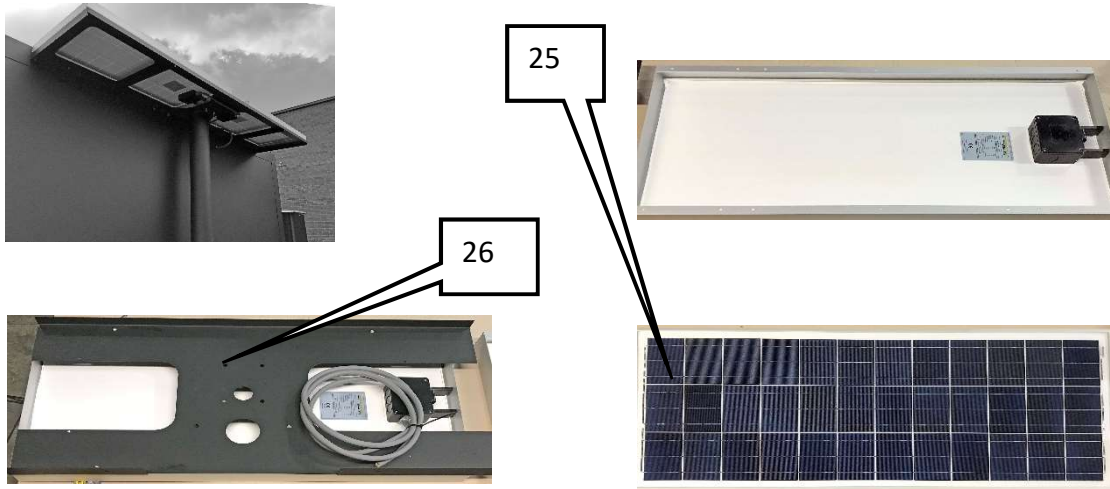

#	Part Description	Part Number
25	Solar panel	CEL-120
26A	Solar panel assembly, single	AMS30045045
26B	Solar panel assembly, double	AMS30045041



3.5 Pedestal Assembly



The pedestal assembly is a double-flange NEMA-style enclosure that is pad lockable and contains the following major components:

Dash Panel

The dash panel contains the sign display “On-Blank” switch, the “Up-Down” toggle switch, battery ammeter and “Push To Reset” 10A fuse. The “On-Blank” switch provides a means of overriding the current message to display no message (blank) without requiring “password” entry into the sign control menu functions. This “blank” mode does not interrupt the solar charging of the batteries.

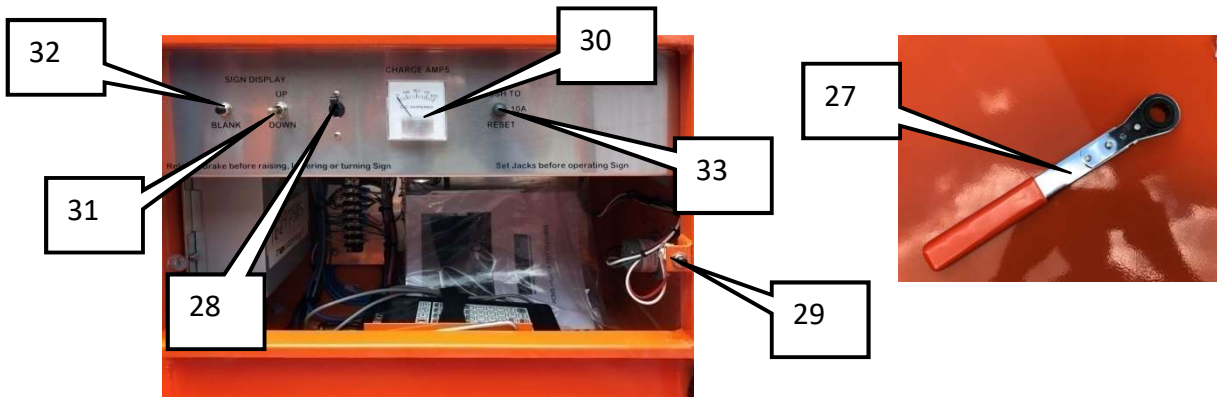

#	Part Description	Part Number
27	Wrench	WRE-10
28	Power switch	SWI-585
29	Courtesy light switch	SWI-70
30	Ammeter	MET-125
31	Hydraulic UP/DOWN switch	SWI-20
32	Blank switch	SWI-70
33	Hydraulic reset	SWI-590
34	Courtesy lamp (behind dash panel)	LAM-40
35	AC sense relay (behind dash panel)	REL126



Charger

A 75-amp charger unit is provided that converts landline 120VAC to 12VDC for charging of the batteries.

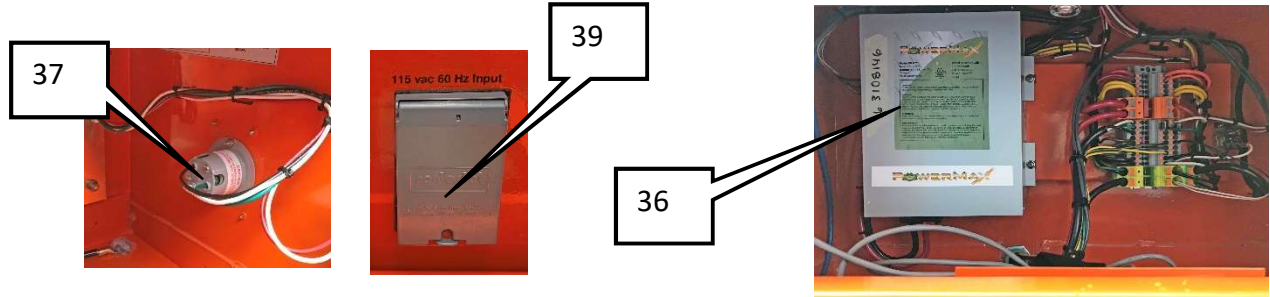

#	Part Description	Part Number
36	75A charger/converter	CHG-155
37	120VAC receptacle	CON-490
38	Handheld terminal	TER-105
39	Receptacle cover	COV-10
40	Umbilical assembly	AMS30121992

Hand-held Terminal

The handheld terminal (HHT) is the device that allows local control of the PCMS and is stored at the bottom of the pedestal assembly. The HHT features a keypad and a backlit LCD display for superior visibility. The HHT is intended to be stored in its cradle inside the pedestal assembly. The HHT's cable is 15' long to allow movement of the operator around the trailer. The HHT can also be detached from the pedestal assembly and stowed in a separate, more secure area. If the terminal is disconnected, the PCMS will continue to operate as previously programmed. The HHT is detached by unscrewing the CPC connector at the top of the terminal.

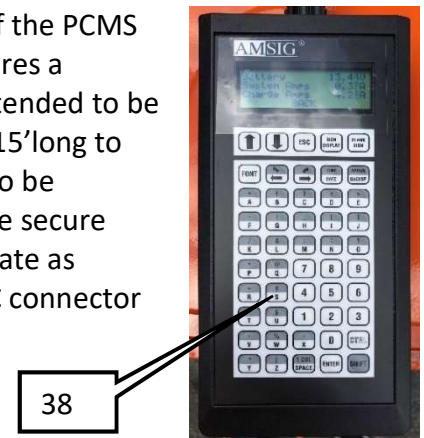

Courtesy Light

A light bulb is located behind the dash panel and shines downward to provide additional light to the pedestal and HHT. A door switch turns the light off when the pedestal door is closed.

Umbilical Assembly

An umbilical assembly connects the sign case and pedestal assembly. This umbilical contains data and power wires and is comprised of watertight, vandal-resistant tubing.

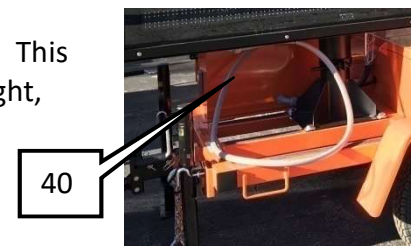



3.6 Tires & Axle

Tires

The Tires are 13" 6 ply tires and mount to the axle hub with 5 lugs on 4-1/2" centers. They are load rated for 1360 lbs. each.

Axle

The Axle is 2000 lb. rated straight idler with 64" hub face distance and 5 lugs on 4-1/2" centers. The suspension is double eye 1200 lb. leaf springs with 53" centers.

3.7 Tongue Assembly

The tongue assembly is a removable tongue that allows the trailer to be towed by other vehicles. A 2" lever-style ball hitch that is rated for 5,000 lbs. and is pinned to a 3" square tube is provided as standard. See Trailer Operation section for more information on the tongue assembly and see the Specification section for more information on the hitch.

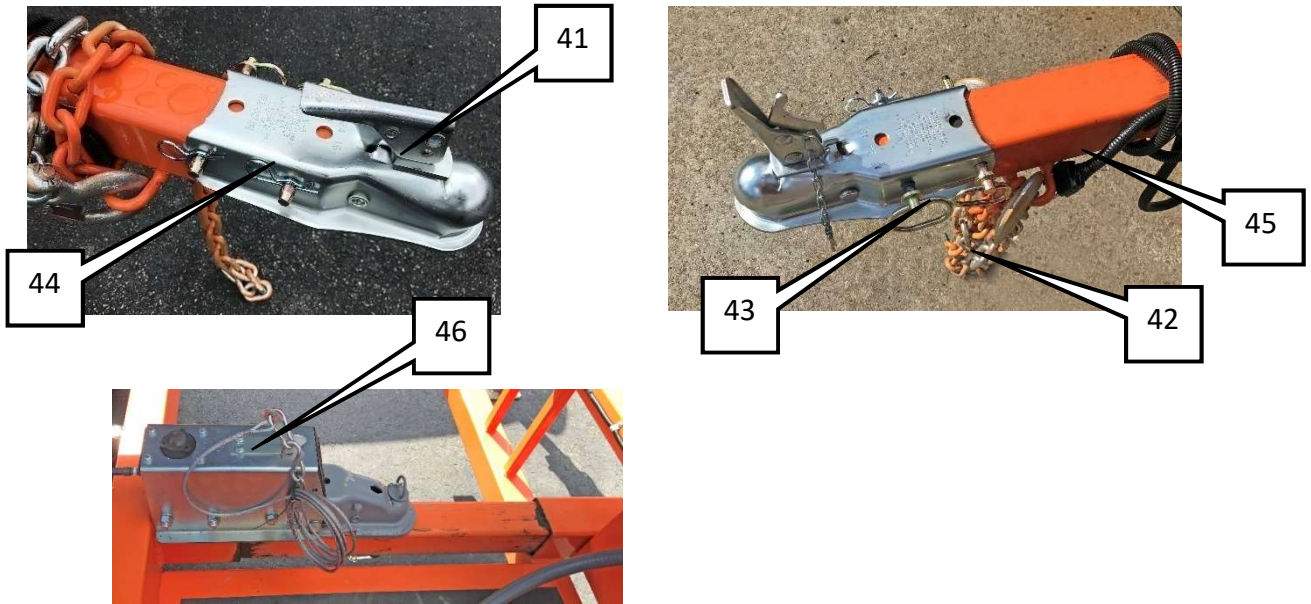

#	Part Description	Part Number
41	2" ball hitch	HIT55-1
42	Safety chains with hooks	AMS30015031
43	Hitch pin	PIN30
44	Cotter pin	PIN130
45	Trailer brake and tail lights harness	HAR195
46	Hitch with optional hydraulic surge brake	HIT-11 (Hit-10 and BRK-30)



AMERICAN SIGNAL COMPANY
 2755 Bankers Industrial Dr.
 Atlanta, GA 30360
 Phone: 770-448-6650
 Fax: 770-448-8970

3.8 Leveling Jacks

The leveling jacks are located at the four corners of the trailer and are top-wind, swivel-mounted jacks used to level and stabilize the PCMS. The jacks are rated for 2000 lbs each and have a travel range of 15”.

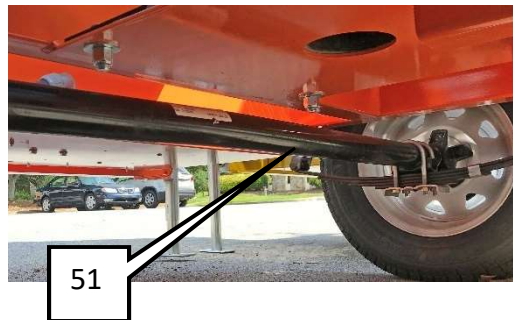
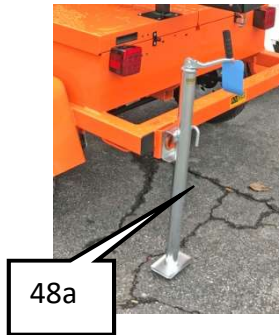
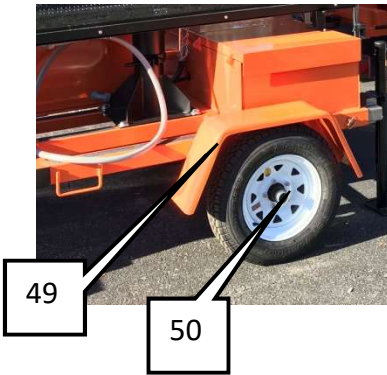

#	Part Description	Part Number
48a	Jack 2000# top-wind swivel mount 15”	JAC85
48b	Jack side-wind mount	JAC-125
49	33x fender	FEN-10
50	Wheel, Tire B78-13ST 6 Ply 1360#	WHE-50
51	Axle, 2000# Straight Idler 64” Hub	AXL-110



3.10 Spare Parts List

AmSig® P/N	Description	Advantage Model		
		232	432	465
Sign Case Assy:				
PNL00000318-x	Display Panel, 18x14 1 LED/Pixel 30 deg	x		
PNL00000307-x	Display Panel, GP-432 2 LED/Pixel 23 deg		x	
PNL00000342-x	Display Panel, 12x6 4 LED/Pixel 23 deg			x
PCB00000085-x	CPU Board, All LED w/ Cell Pwr Save	x	x	x
POW00000330	Power Supply, 12VDC In 3.3VDC Out	x		
POW00000405	Power Supply, 10.5-16VDC In 6.0VDC Out		x	
PCB00000265-x	Photosensor Board, LED	x	x	x
PLA00000335-1	Polycarb lens	x		
AMS30060157	Polycarb, .236" x 44.639" x 74.917"		x	
PLA00000310-1	Polycarb lens			x
CEL00000135	Blue Sky	x	x	x
Hydraulic Pump and Cylinder:				
HYD00000160	Hydraulic Pump, Combo 12V + Lever	x	x	x
HYD00000275	Cylinder, Hydraulic 1-1/4 Bore 44" Stroke	x	x	x
Solar Panel Assembly:				
CEL00000120	Solar Panel, 80W @17.1V	x	x	x
Pedestal Assembly:				
TER00000105	Terminal, Handheld Keyboard "98"	x	x	x
CHG00000155	Charger, 75/80A 120V 13.2V to 14.4V	x	x	x
Trailer Assembly:				
BAT00000140	Battery, 6V Deep Cycle 215 Amp-Hrs	x	x	x
FUS00000325	Fuse, Circuit Breaker 90A	x	x	x
WHE00000050	Wheel, Tire B78-13ST 6 Ply 1360#	x	x	x
AXL00000110	Axle, 2000# Straight Idler 64" Hub	x	x	x
AMS30120478	Tongue Assembly, x32 Advantage	x	x	x
HIT00000055-1	Hitch, 2" Ball Socket Lever w/Pin	x	x	x
JAC00000085	Jack, 2000# Top Wind Swivel Mount 15"		x	
JAC00000125	Jack, 2000# Side Wind Swivel Mount 15"	x		x
LAM00000020	Lamp, Tail Left Side	x	x	x
LAM00000030	Lamp, Tail Right Side	x	x	x
Miscellaneous:				
WRE00000010	Wrench, Box Ratchet 5/8" x 11/16"	x	x	x
BIT00000190	Bit, Torx 1/4" Pin-In-Head Screw	x	x	x

NOTE: P/Ns with revisions are denoted with an "-x" suffix. Call factory for applicable (or current) revision level.



AMERICAN SIGNAL COMPANY
2755 Bankers Industrial Dr.
Atlanta, GA 30360
Phone: 770-448-6650
Fax: 770-448-8970

4.0 Advantage System Maintenance

4.1 Sign Case Assembly Maintenance

The CPU, power manager and any additional communication equipment are located on an equipment tray in the sign case. The display panels are also located in the sign case. The LED display panels do not need maintenance, however if an LED is not operating the panels can be removed and replaced.

To access and replace panels in the 232 sign case

- If the sign case is lowered, it must first be raised slightly (1"-2") above the cradle to allow opening of the door.
- Loosen captive socket head cap screws at bottom of door.
- Lift open door and use prop rod on the right side of inside sign case to prop door assembly open. Put tube end of prop rod onto bent rod in sign case. Place the other end of prop rod with straight pin into hole in side of door frame.

*** * * CAUTION * * ***

DO NOT disconnect or reconnect display panels with sign power ON

- Remove the two MTA data/power connectors from the rear of the display panel.
- Unscrew the nylon wing nuts holding the display panel to the Lens.
- When removing display panel(s), it may require the removal of more than just that Panel to be serviced since they are layered together when assembled at the factory.
- Reverse process to install replacement LED display panel.



To access and replace panels in the 432 & 465 sign case

- If the sign case is lowered, it must first be raised slightly (1"-2") above the cradle to allow opening of the door.
- Open the sign case door and hinged pan.
 - Loosen captive socket head cap screws at bottom of door.
 - Lift open door and use prop rod on left or right side of inside sign case to prop door assembly open. Put tube end of prop rod onto bent rod in sign case. Place the other end of prop rod with straight pin into hole in side of door frame.
 - Remove two screws and washers on lower left and lower right of hinged pan.
 - Lift open hinged pan and use remaining prop rod to prop hinged pan with display panels open. Put tube end of prop rod onto bent rod in sign case. Place the other end of prop rod with straight pin into hole in hinged pan bar at bottom of hinged pan.

To access and replace panels in the 232 sign case

- If the sign case is lowered, it must first be raised slightly (1"-2") above the cradle to allow opening of the door.
- Open the sign case door and hinged pan.
 - Loosen captive socket head cap screws at bottom of door.
 - Lift the door and remove two screws and washers on lower left and lower right of hinged pan.
 - Lift the hinged pan and remove the prop rods from each side of the case.

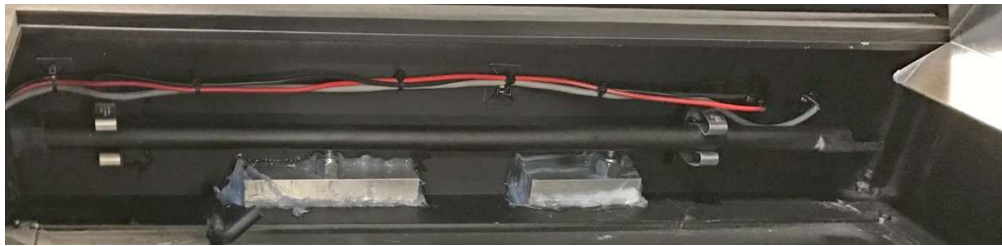

- Lift open door and use prop rod on left or right side of inside sign case to prop door assembly open. Put tube end of prop rod onto bent rod in sign case. Place the other end of prop rod with straight pin into hole in side of door frame.
- Lift open hinged pan and use remaining prop rod to prop hinged pan with display panels open. Put tube end of prop rod onto bent rod in sign case. Place the other end of prop rod with straight pin into hole in hinged pan bar at bottom of hinged pan.



***** CAUTION *****

DO NOT disconnect or reconnect display panels with sign power ON

- Remove the MTA data/power connector from the rear of the display panel and lower the hinged pan back to the closed position.
- Remove black screws holding the display panel to the hinged pan.
- Reverse process to install replacement LED display panel.



Door propped open

Screws holding LED display panel in place

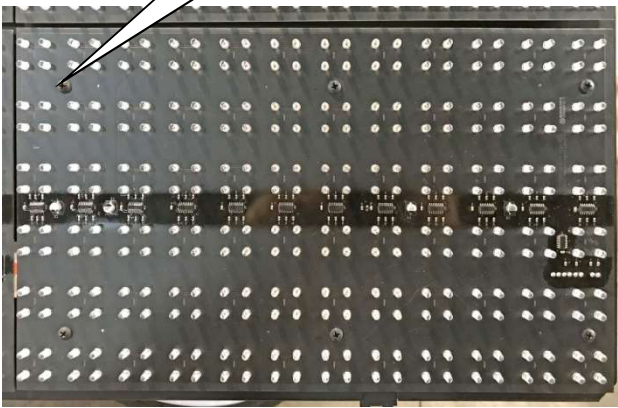

Hinged pan open

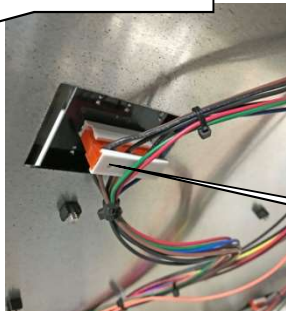

MTA connector





To access the equipment tray to replace the CPU:

Follow the access procedure for replacing LED panels

- Disconnect all connections on the CPU.
- Remove the nylon nuts that secure the CPU to the equipment tray.
- Remove the CPU and install the new CPU board on the studs in the equipment tray.
- Reuse the nylon nuts to secure the new CPU board to the equipment.
- Reconnect all electrical connections to the new CPU board.
- To close sign case after accessing the equipment tray or display panels, reverse the steps shown above.

432 & 465



232



Lens Maintenance

In order to provide maximum visibility and clarity, the lens should be cleaned periodically. It is recommended that the lens be cleaned with a mild soap and water solution, using a soft cloth so as not to scratch the lens.

If the lens is damaged (cracked or severely scratched) or visibility is impaired, it can be removed and replaced. To remove the lens, open the sign case door and prop open with provided prop rod mounted on the inside of the sign case. Take out the lens retaining plates on the inside sides and bottom of the door frame. Once these plates are removed, the lens will drop out of the door frame. Replace new lens with anti-glare treated surface facing out.

4.2 Hydraulic Pump Maintenance

In order for the hydraulic pump to operate correctly, it requires adequate quantities of hydraulic fluid. The level of fluid in the holding tank on the pump should be periodically checked and refilled to 1" below the filler opening if low. Also check the hose and fittings for leaking and repair if necessary.



4.3 Solar Panels

- To ensure optimal charging capability the solar panel should be exposed to as much sunlight as possible. Storing or deploying your PCMS under a tree, bridge, or other object that restricts sunlight will negatively impact the PCMS run time
- Keep the solar panel's surface clear of debris, dirt, and ice by wiping the surface with a non-abrasive material (such as cloth or paper towels) as necessary.
- Do not scrape the solar panel to remove build-up, as that may damage the solar cells.
- Do not apply industrial type cleaning fluids or solutions to the surface of the solar panel. If a rag or cloth is not sufficient to clean the surface then apply warm water or household type cleaner such as Windex.

4.4 Battery Maintenance

During operation (particularly in the summer months), it is necessary to ensure that the battery electrolyte level is properly maintained.

During the winter months, it is necessary to ensure that the battery state of charge remains above the level necessary to prevent the batteries from freezing. When temperatures below freezing are forecast, test the electrolyte levels in the batteries using a hydrometer. The voltage level alone is not an accurate indicator of electrolyte freezing temperature. A chart in the Specification section shows how to determine electrolyte freezing points at various hydrometer readings. In the event the hydrometer reading shows that the specific gravity of the electrolyte is low enough to allow the batteries to freeze, it may be necessary to recharge them.

Stratification

Stratification occurs when the batteries have not moved over a long period of time and the electrolyte fluid in the battery begins to separate. Stratification results in only the lower parts of the battery cells doing the work causing reduced battery capacity and life. The electrolyte stratification that occurs in wet batteries, standing still at float voltages, can be reduced by inserting the dual voltage plug into the charger. The dual voltage plug allows for occasional fast charging at 14.2VDC and can cause the batteries to bubble for a few hours. Be sure to check and maintain the water levels in the batteries before and after the bubbling charge. After the fast charge, remove the dual voltage plug to avoid boiling the batteries dry. See Specification section for more information on charger.

Stratification does not occur in batteries which are jostled by frequent moving of the vehicle they are mounted in.



AMERICAN SIGNAL COMPANY
2755 Bankers Industrial Dr.
Atlanta, GA 30360
Phone: 770-448-6650
Fax: 770-448-8970

Detailed Sequence of Battery Charging Actions

- Make sure you wear protective clothing and a face shield when doing any kind of maintenance or charging of battery system.
- Disconnect battery cables.
- Wash dirt off the top of the batteries.
- Measure the specific gravity of all cells and remove those batteries having more than .050 variation between the cells.
- Reconnect the battery cables to allow charging of those remaining.
- Be sure that all remaining battery cells have sufficient electrolyte to cover the plates plus $\frac{1}{4}$ of an inch. Use only distilled or deionized water.
- Connect 120VAC to the covered receptacle on right side of pedestal assembly.
- Do a “dirty connection” check by using a sensitive DC voltmeter to measure the voltage drop between the battery posts at the ends of each jumper cable of the battery pack. If there are more than 4 millivolts drop from post to post, then disconnect the 120VAC from the receptacle and clean and reconnect the cable connections.
- Reconnect the 120VAC to the pedestal receptacle.

After batteries become fully charged (specific gravity 1.25 +/- .010 with a temperature compensated hydrometer), replace those which were rejected with good, fully charged batteries of the SAME brand and size as the rest of the pack.



AMERICAN SIGNAL COMPANY

2755 Bankers Industrial Dr.

Atlanta, GA 30360

Phone: 770-448-6650

Fax: 770-448-8970

IMPORTANT NOTES:

- Electrolyte level in the batteries should be checked before and after each charging in addition to regular, periodic examinations. Replenish electrolyte with either distilled or de-ionized water up to the bottom of the 'fill' vent tube, but no higher. Note: adding water just before taking hydrometer readings will yield erroneous readings.
- A battery having a lesser or greater charge level than the pack must not be connected to that pack. To do so risks battery explosion.
- Any sparking as the cables are being connected indicates uneven charging and may ignite an explosion.
- Charging to specific gravity readings above 1.265 will cause damage to the battery plates.
- For proper charging and electrolyte destratification, allow charging, from the 120V line, to continue until the charging voltage drops back from 14.1V+/- to 13.2V+/- . Note that at the start of charging, the charging voltage may be 13.2V, more or less, but will be rising rather than dropping back.
- Batteries allowed to be abused by being discharged below the "required blank state" level will require considerable time on the charger just to bring them up to a condition in which they can begin to accept a charge. Under certain low temperature conditions, excessive discharging can permanently damage the batteries due to freezing. Charging of damaged batteries can cause a potentially dangerous condition for personnel and equipment. Therefore, maintain a good charge level in the batteries during cold weather because lead/acid batteries can freeze and can be ruined if they are sufficiently discharged.
- Interruptions of the 120VAC supply line may cause the charger to reset which will lengthen the charging time. It may be necessary to disconnect both AC and DC from the charger, put a load on the batteries to burn off any surface charge and then reconnect the batteries and 120VAC to restart the charger.
- 12GA 120VAC inlet cords (min.) should be used with the 75A chargers.
- 120VAC generators used with these chargers should be rated at 5KW, heavy duty (min.).



AMERICAN SIGNAL COMPANY
2755 Bankers Industrial Dr.
Atlanta, GA 30360
Phone: 770-448-6650
Fax: 770-448-8970

4.5 SEASONAL STORAGE

Fully charge and fully deplete batteries while in storage. If the sign is in storage for longer than a month, take the following measures to insure optimal battery and sign performance:

1. Blank the sign display.
2. On a full battery charge, leave the sign unused for 30 days.
3. Use the AC adapter to charge the batteries for 2 days.
4. Repeat the 30/2 cycle for the duration of storage.

Letting the batteries die for an extended period of time may prevent them from holding a charge again. In a blanked state, the batteries may last longer than 30 days before running out of a charge, but we schedule the charging to coincide with regular monthly maintenance for user convenience.

4.6 Mast

When pulling a sign in from the field for either storage or maintenance the user may notice the mast is rusted and/or dry from being exposed to weather.

- DO NOT use liquid lubrication on the mast to assist in the lowering process.
- Amsig recommends a **spray on industrial graphite dry lubricant** for mast lubrication.
- If hydraulic operation is not possible for some reason, call our Service Department immediately.

5.0 Wiring Diagrams

The following pages contain the system wiring diagrams for the various Advantage Series Trailers.



AMERICAN SIGNAL COMPANY
 2755 Bankers Industrial Dr.
 Atlanta, GA 30360
 Phone: 770-448-6650
 Fax: 770-448-8970

5.1 Model 232 Advantage

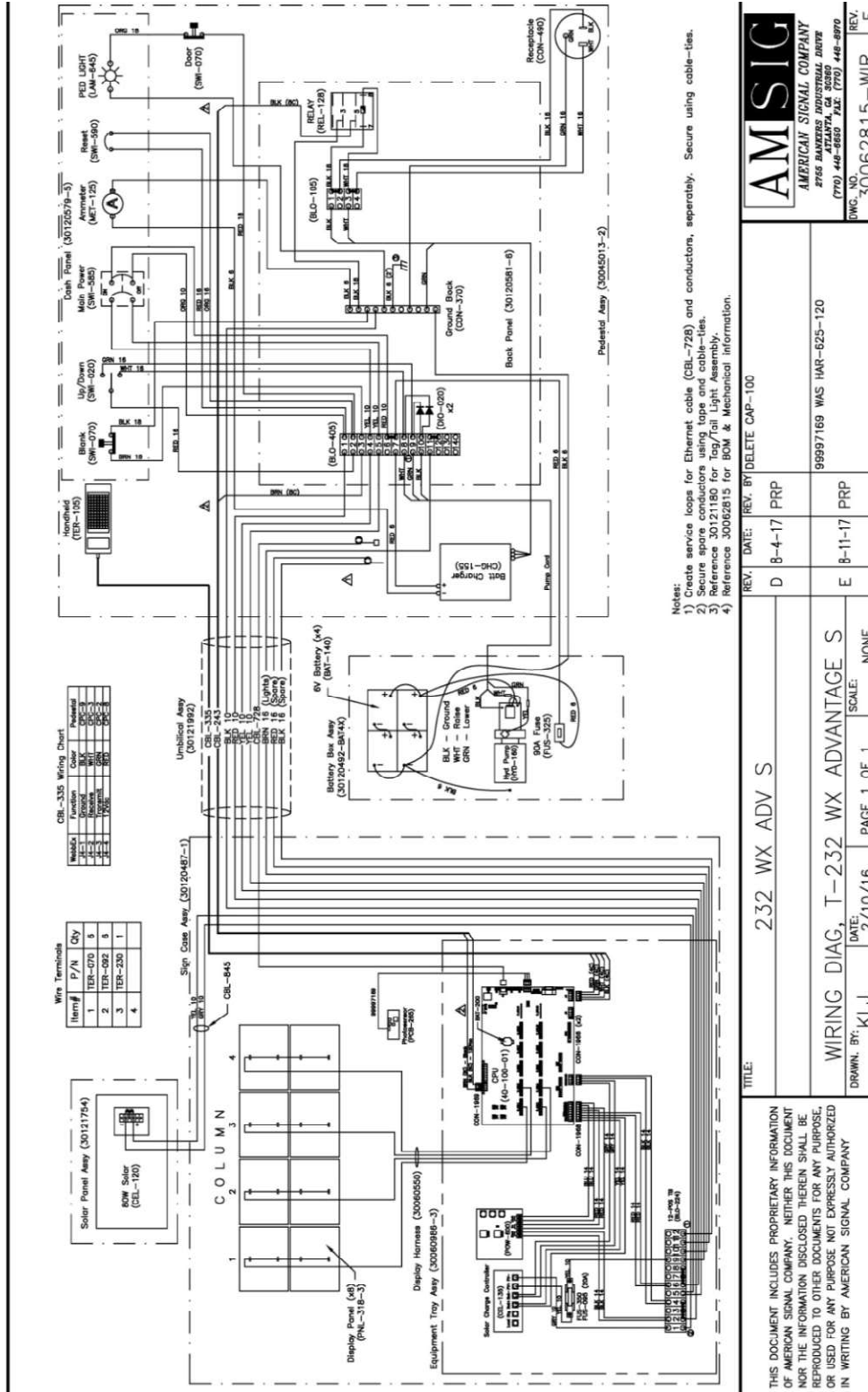

- Notes:
- 1) Create service loops for Ethernet cable (CEL-728) and conductors, separately. Secure using cable-ties.
 - 2) Secure spare conductors using tape and cable-ties.
 - 3) Reference 30121180 for Tag/Light Assembly.
 - 4) Reference 30062815 for BOM & Mechanical information.

		AMERICAN SIGNAL COMPANY 2755 BANKERS INDUSTRIAL DRIVE ATLANTA, GA 30360 (770) 448-6650 FAX: (770) 448-8970 DWG. NO. 30062815-WIR REV. E	
TITLE: 232 WX ADV S		REV. DATE: REV. BY DELETE CAP-100 D 8-4-17 PRP	
WIRING DIAG, T-232 WX ADVANTAGE S		99997169 WAS HAR-625-120	
DRAWN BY: KLU		DATE: 2/10/16	
SCALE: NONE		PAGE 1 OF 1	
THIS DOCUMENT INCLUDES PROPRIETARY INFORMATION OF AMERICAN SIGNAL COMPANY. NEITHER THIS DOCUMENT NOR THE INFORMATION DISCLOSED THEREIN SHALL BE REPRODUCED TO OTHER DOCUMENTS FOR ANY PURPOSE, OR USED FOR ANY PURPOSE NOT EXPRESSLY AUTHORIZED IN WRITING BY AMERICAN SIGNAL COMPANY			



AMERICAN SIGNAL COMPANY
 2755 Bankers Industrial Dr.
 Atlanta, GA 30360
 Phone: 770-448-6650
 Fax: 770-448-8970

5.2 Model 432 Advantage

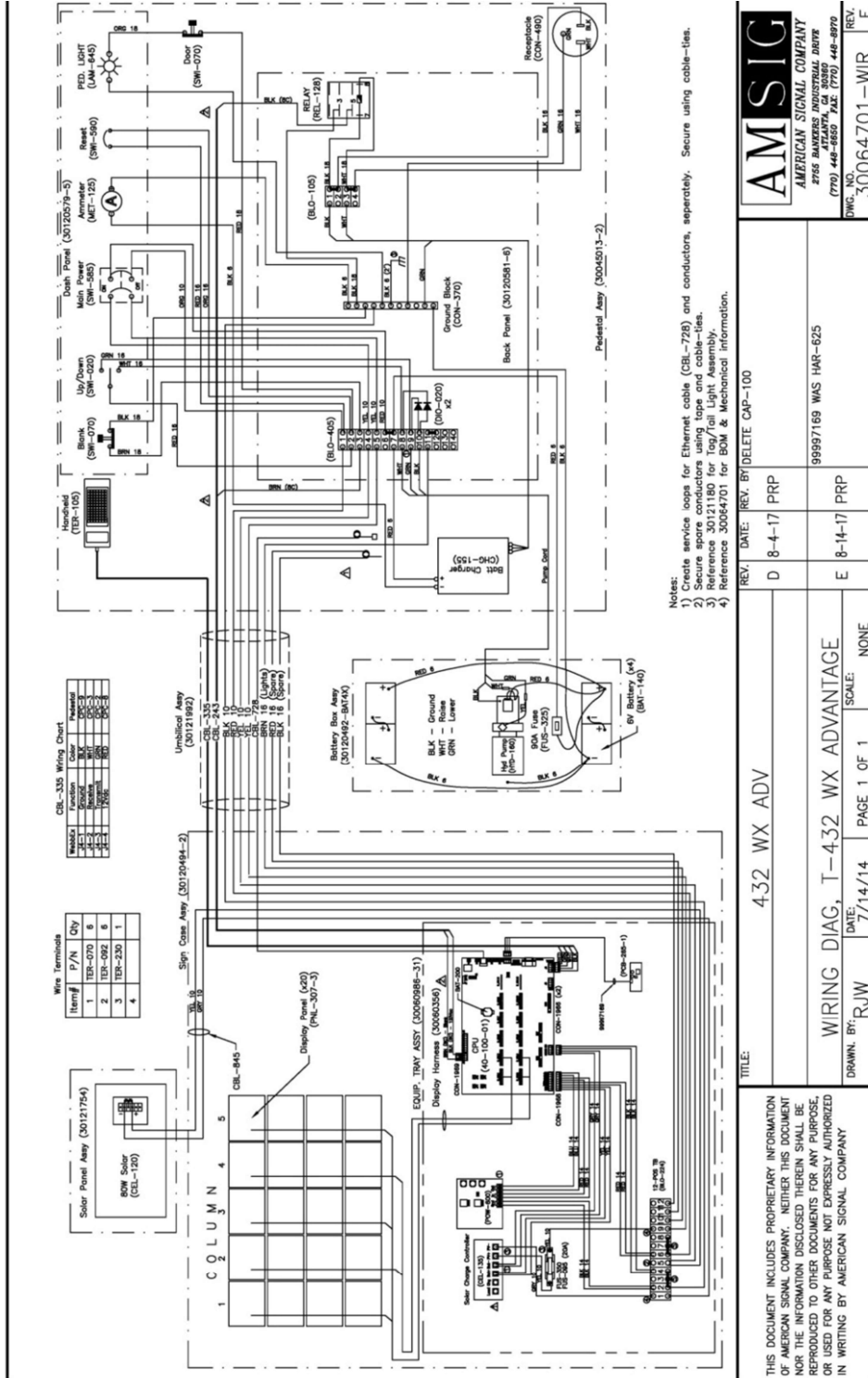

- Notes:
- 1) Create service loops for Ethernet cable (CBL-728) and conductors, separately. Secure using cable-ties.
 - 2) Secure spare conductors using tape and cable-ties.
 - 3) Reference 30121180 for Top/Tail Light Assembly.
 - 4) Reference 30064701 for BOM & Mechanical Information.

<p>AMERICAN SIGNAL COMPANY 2755 BANKERS INDUSTRIAL DRIVE ATLANTA, GA 30360 (770) 448-6650 FAX (770) 448-8970</p>	REV: DATE: REV. BY: DELETE CAP-100	D 8-4-17 PRP	99997169 WAS HAR-625
	TITLE: 432 WX ADV WIRING DIAG, T-432 WX ADVANTAGE DRAWN BY: RJW DATE: 7/14/14 PAGE 1 OF 1 SCALE: NONE		E 8-14-17 PRP
THIS DOCUMENT INCLUDES PROPRIETARY INFORMATION OF AMERICAN SIGNAL COMPANY. NEITHER THIS DOCUMENT NOR THE INFORMATION DISCLOSED THEREIN SHALL BE REPRODUCED TO OTHER DOCUMENTS FOR ANY PURPOSE, OR USED FOR ANY PURPOSE NOT EXPRESSLY AUTHORIZED IN WRITING BY AMERICAN SIGNAL COMPANY.			



AMERICAN SIGNAL COMPANY
 2755 Bankers Industrial Dr.
 Atlanta, GA 30360
 Phone: 770-448-6650
 Fax: 770-448-8970

5.3 Model 465 Advantage

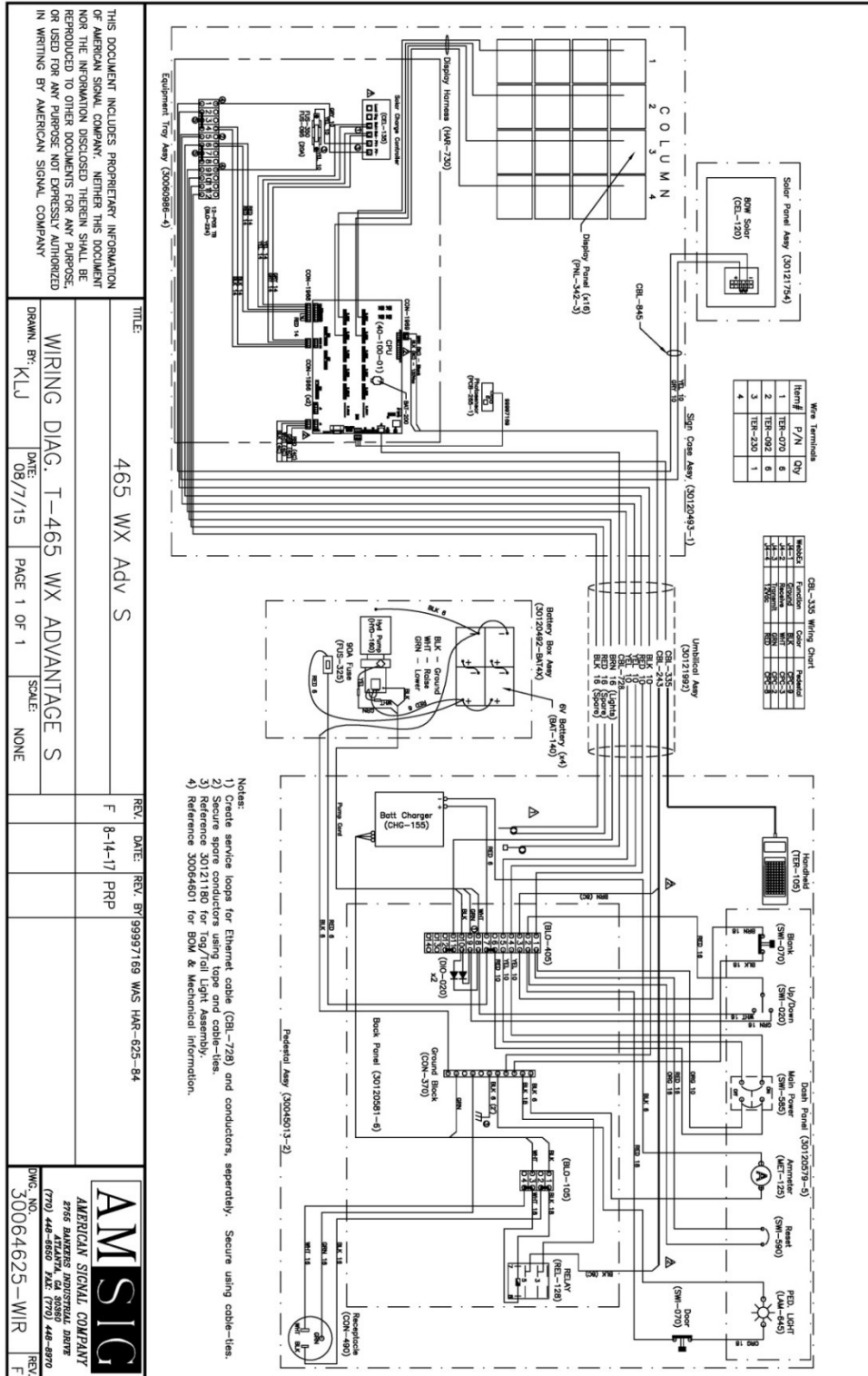

THIS DOCUMENT INCLUDES PROPRIETARY INFORMATION OF AMERICAN SIGNAL COMPANY. NEITHER THIS DOCUMENT NOR THE INFORMATION DISCLOSED THEREIN SHALL BE REPRODUCED TO OTHER DOCUMENTS FOR ANY PURPOSE, OR USED FOR ANY PURPOSE NOT EXPRESSLY AUTHORIZED IN WRITING BY AMERICAN SIGNAL COMPANY.

TITLE:		465 WX Adv S	
DRAWN BY:		KLJ	
DATE:		08/7/15	
PAGE:		1 OF 1	
SCALE:		NONE	
REV.:	DATE:	REV.:	DATE:
F	8-14-17	PRP	
REV. BY:		BT 99997169 WAS HAR-625-84	
DWC NO.:		30064625-WIR	
AMERICAN SIGNAL COMPANY		AMERICAN SIGNAL COMPANY	
2755 BANKERS INDUSTRIAL DRIVE		2755 BANKERS INDUSTRIAL DRIVE	
(770) 448-6650 FAX (770) 448-8970		(770) 448-6650 FAX (770) 448-8970	



AMERICAN SIGNAL COMPANY
2755 Bankers Industrial Dr.
Atlanta, GA 30360
Phone: 770-448-6650
Fax: 770-448-8970

6.0 Mechanical Drawings

The drawing numbers for the sales drawings are shown below:

Model #	Drawing #
232	30062815A
465	30064601B
432	30064701C



7.0 Trouble Shooting

ISSUE	POSSIBLE CAUSE(S)	SOLUTION
LED panel does not display	faulty LED panel; faulty panel cable harness	Switch panel with a known good panel. If suspected faulty panel still does not display then panel needs to be replaced. If known good panel does not display then cable harness likely needs to be replaced
Terminal displays "Low Voltage Lockout"	system battery voltage is too low to power sign (below 11.2 V)	Apply AC power to trailer until onboard ammeter reads 0 (typically 2-3 days, depending on the size of your battery bank).
Sign enters "Low Voltage Lockout" regularly	poor solar exposure; expired batteries	Move unit to area with more solar exposure to solar panels. Monitor "Charge Amps" field in "Status" screen. Use a hydrometer to test each cell of each battery (lead acid type batteries only).
Display remains too bright/dim after change in ambient lighting	"Brightness" setting is set to "Manual" instead of "Auto"	Change "Brightness" mode in "Admin" menu from "Manual" to "Automatic".
LED's or characters remain on, or display "junk" characters	static on cable harness; faulty LED panel	Reboot unit's main power and observe display. If problem persists, switch panel with a known good panel and observe display.
Can no longer connect to sign remotely via cell modem	cell carrier error; poor cellular signal; faulty modem; faulty CPU	Confirm account validity with carrier. Ping IP address. Enter modem interface page to view cell signal strength.
"Failed to Load" error message over Web Control	incompatible browser; outdated firmware	Use Google Chrome or Mozilla Firefox for Web Control. Contact our Service Department for the latest version of our Webb Express firmware



AMERICAN SIGNAL COMPANY
2755 Bankers Industrial Dr.
Atlanta, GA 30360
Phone: 770-448-6650
Fax: 770-448-8970

8.0 Service Contact

Online Support: <http://amsig.com/support/>, where you will find manuals, quick guides, and other resources. You can also submit an inquiry through our website at <http://amsig.com/contact-us/>.

Email: service@amsig.com

Phone: 770.448.6650 (use extension 3 to reach the Service Department)

Fax: 770.448.8970

Write: American Signal Company – Service Department

2755 Bankers Industrial Drive

Atlanta, GA 30360