



PORTABLE FLASHING ARROW PANELS

15- and 25-lamp, Types B & C

MODELS T615, T625, T815, T825

CATALOG NUMBERS SUBJECT TO CHANGE

FEATURES

- 15-lamp and 25-lamp configurations
- Type B (3'x6') and Type C (4'x8')
- High-Intensity LED Lamps
- Indicator LED lamps on rear of display
- Wireless Controller
- AC Charger
- Maintenance-Free Batteries
- Vandal-Resistant Battery Cabinet
- Heavy-Duty Steel Frame
- Superior foot-print for maximum deployed stability
- Superior Power Management
- Simple & secured hand-held controller

DISPLAY CHARACTERISTICS

- Flashing & Sequential* Arrows
- Double Arrow
- Flashing & Sequential Chevrons*
- Caution Bar
- Caution Beacons
- Alternate Diamonds*

**indicates 25-lamp model only*



GENERAL SPECIFICATIONS

American Signal Company's Flashing Arrow Panel products feature an all-LED, 15- or 25-lamp trailer mounted display. These arrow board trailers are equipped with a high-wattage solar panel and maintenance-free battery bank. The Amsig FAP product line encourages motorist awareness and work zone safety, and is well suited for both highway and urban use.

OPTIONS

- Multiple towing hitch options
- Expanded battery bank for greater run time
- Trailer color options
- Tandem towing package
- Security measures – locking lug nuts, wheel lock



2755 Bankers Industrial Dr. Atlanta, GA 30360

PHONE: 770.448.6650 FAX: 770.448.8970

info@amsig.com / www.amsig.com



PORTABLE FLASHING ARROW PANELS

15- and 25-lamp, Types B & C

MODELS T615, T625, T815, T825

CATALOG NUMBERS SUBJECT TO CHANGE

MODEL	LAMPS	SIZE	VISIBILITY
T615	15	TYPE B, 3'X6'	3/4 MILE
T625	25	TYPE B, 3'X6'	3/4 MILE
T815	15	TYPE C, 4'X8'	1 MILE
T825	25	TYPE C, 4'X8'	1 MILE

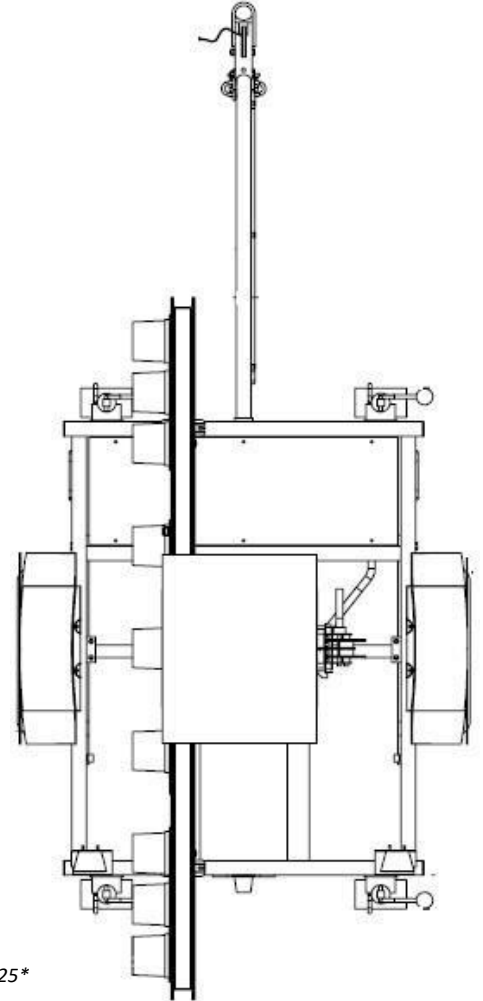
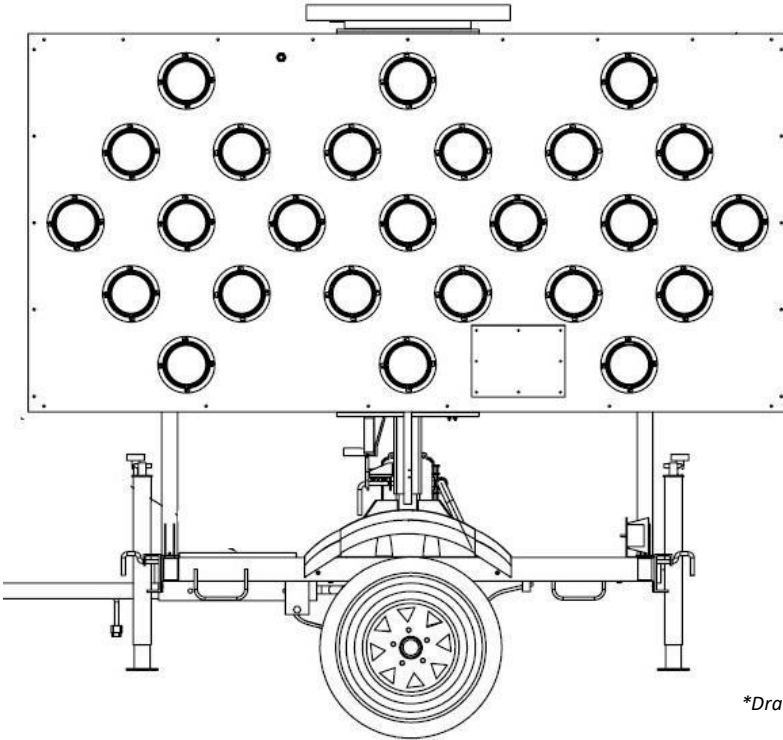

Drawings are of Amsig model T825

TRAILER

Height	93" (storage & travel)	120-132" (deployed)
Length	119" (travel)	56" (w/ tongue removed)
Width	63"	
Trailer Frame	Steel Tube	2"x3" ASTM A 500 Grade B
Battery & Control Cabinet	Secured, NEMA-style	
Solar	40W	Options Available
Batteries	8x12VDC Sealed Lead Acid	Options Available
Hitch	2" ball	Options Available



2755 Bankers Industrial Dr. Atlanta, GA 30360

PHONE: 770.448.6650 FAX: 770.448.8970

info@amsiq.com / www.amsiq.com