

Advantage GP Series 232T/Y/S

All LED Full Matrix /Graphics General Purpose Changeable Message Sign

Product Specifications

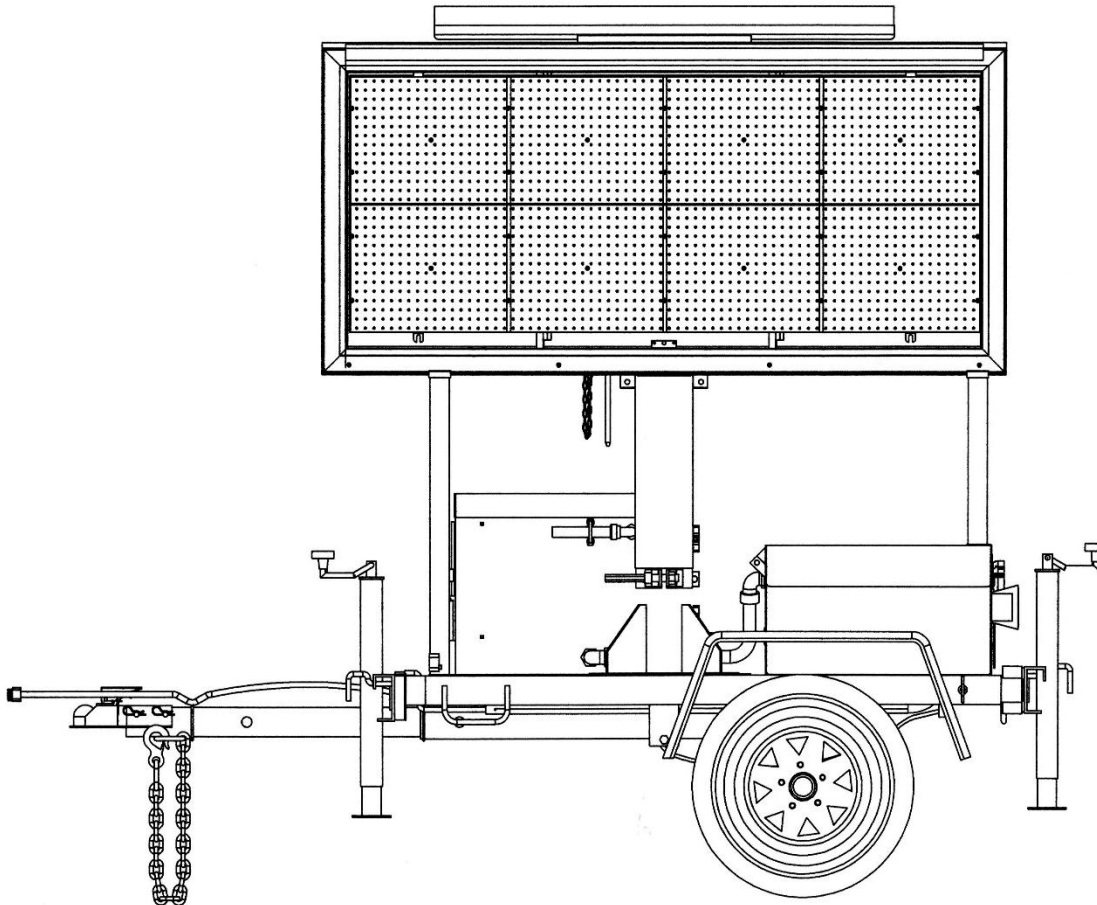



*2755 Bankers Industrial Drive
Atlanta, GA 30360
Phone: 770-448-6650
Fax: 770-448-8970*

1. SCOPE

This specification defines the characteristics and features of an all LED, full matrix general purpose changeable message sign that is capable of both static and dynamic graphics, full display sized messages, and conventional one, two, three, or four-line message display with a choice of eleven font sizes.

- The sign may be **truck mounted (232Y)**, either at the rear of a flatbed or behind the cab (mid bed) of either a flatbed or pick-up.
- Additionally, the sign may be **trailer mounted (232T)**.
- When **truck mounted**, the sign system is compatible with charging of the 12 VDC power source battery pack from the vehicle charging system, or
- When **trailer mounted** is compatible with a solar charging system in conjunction with a standard 110 VAC charging capability.
- The sign system may, as an option, be equipped for remote operation through remote communications; cellular, RF wireless, CDPD, Satellite, etc.
- The sign system may also be utilized to display dynamic, in situ traffic speeds through use of the optional traffic radar transducer and resident software, or may display downstream traffic congestion information utilizing optional queue detection in conjunction with resident software.
- In addition the sign may be outfitted with any ITS (Intelligent Transportation System) style device including; CCTV, HAR, & RWIS.
- Meets or exceeds standards set forth in:
 - FHWA
 - MUTCD
 - NTCIP Version 2

IMPORTANT FEATURES:

- Heavy duty all steel welded trailer frame to ensure long life and excellent durability
- Two-coat automotive paint process to protect it from weather and road hazards
- Single piece polycarbonate plastic lens with front surface screened matte black to reduce glare

2. MESSAGE SIGN DISPLAY

2.1. Description:

- The 232T/Y/S is a twenty-eight (28) pixel row by seventy-two (72) column, Full Matrix, LED Display
- Each display shall be configured of all light emitting diode (LED) with each having operational characteristics of Amber 590nm LEDs with a 30° cone of angularity.
- The display shall consist of 8 panels - two lines, each of which shall contain four display panels.
- Panel size – 13.15” High by 16.60” wide
- The display panels shall be uniformly spaced horizontally across the display face.
- Each line of display has a pixel configuration of 14 pixel rows high by 72 pixel columns wide.
- Each line is equally separated.

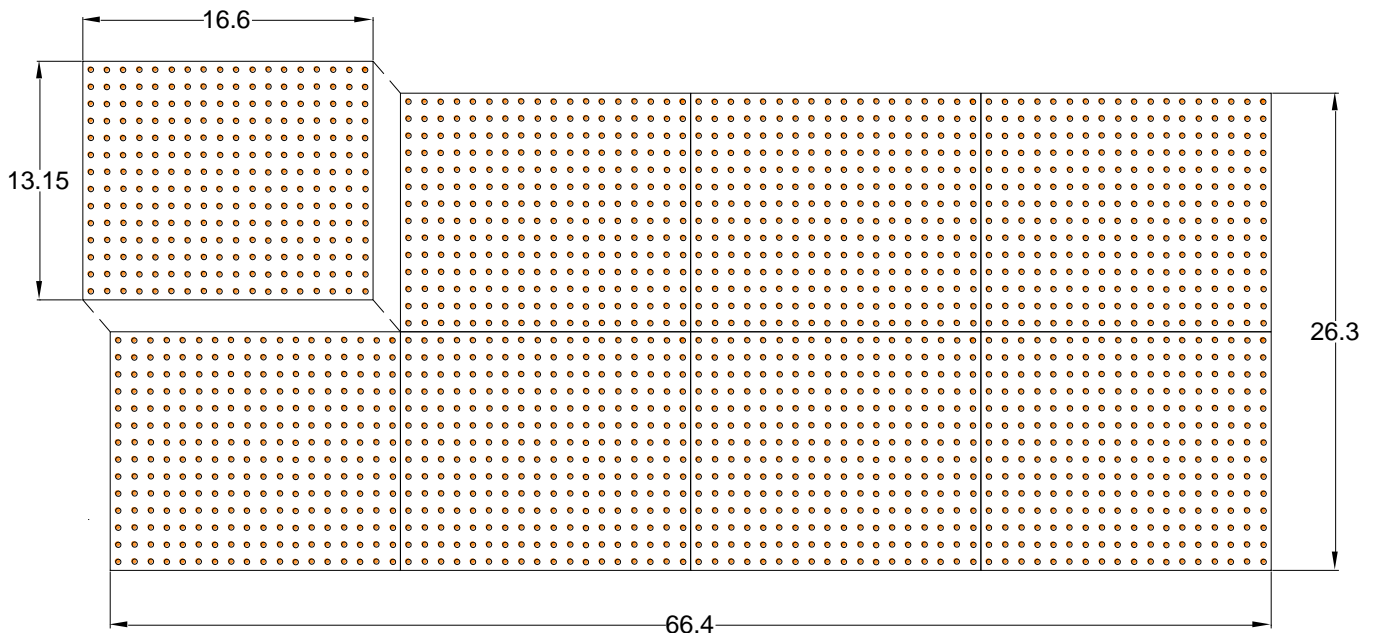

2.2. Display Panels:

- Each display panel shall be 100% solid state with no moving parts or switches, shall be identical to, and mutually interchangeably with, all other panels.
- No field hardware or programming modifications shall be required to exchange or replace individual display panels.
- Each display panel shall contain the LED driver circuitry necessary to operate its associated LED's
- There shall be no separate driver boards between the display panels and the central processing unit (CPU).
- Each individual panel shall have the following layout characteristics specific to the sign type.
 - 1 LED per Pixel
 - Pixel Layout per Panel – 14 Rows X 18 Columns
 - Pixel Spacing – .95” High X .90” Wide
 - LED Angularity – 30 degrees
- Each panel shall be able to monitor and determine pixel failure.
- Pixel failure will be represented on host software and local control system identifying location of failed pixel.
- Controller display will be in WYSIWYG format, (What You See Is What You Get.).



2.3. LED Pixels:

- The individual pixels shall be comprised of ITE amber (approx. 592 nm) LED providing both daytime and nighttime legibility.
- LED's shall be rated for a 100,000 hour service life and shall have an operating temperature range of - 22 degrees F. to + 165 degrees F.
- General Characteristics
 - Number of Pixels: 72 standard, 6 pixels rows, 12 pixel columns
 - Number of LED's per pixel: 1 standard
 - Operating Voltage: 12VDC nominal
 - Brightness Control: Pulse width modulation
 - Current Limiting: One external resistor per driver
 - LED Driver: Power shift register technology
 - Temperature Range: -40° F to +165° F

Font	Nominal Height	Character/Line	Lines/Sign Face	Legibility Distance
3 x 5	5"	18	4	300 ft.
4 x 5	5"	14	4	300 ft.
3 x 7	7"	18	3	400 ft.
4 x 7	7"	14	3	400 ft.
5 x 7	7"	12	3	500 ft.
5 x 7W	7"	10	3	500 ft.
7 x 7	7"	9	3	500 ft.
7 x 7W	7"	8	3	500 ft.
6 x 11	10.5"	10	2	650 ft.
7 x 20	19"	9	1	1,000 ft.
9 x 20	19"	7	1	1,100 ft.

2.4. Display Power Supply:

- The power supply for the display shall be sufficient to operate the LED pixels for both daylight and nighttime conditions.
- It shall be suitably regulated and temperature stable.
- It shall be fully operational in the temperature range of - 30 degrees F. to + 165 degrees F.

2.5. Panel Wiring:

- The display panel wiring shall be comprised of one wiring harness for each column of display panels with positive locking connectors at the CPU and at the individual display panels.
- The harnesses shall be comprised of twenty gauge, or larger, individual conductors (no ribbon cables), and shall be configured so as to preclude data from a malfunctioning display panel column being transmitted to and corrupting any other display panel column in the sign display.



3. 12 VDC POWER SOURCE

3.1. Description: The 12 VDC power source for the sign system shall be provided by a 12 V DC lead/acid battery bank as follows:

3.1.1. Trailer Mounted System:

- The trailer-mounted system shall be provided with a dedicated battery pack consisting of the following banks
 - Battery Type - 6 VDC marine/RV type 4-D deep cycle
 - 20° Amp Hour Rating – 215A
 - Number of Batteries – 2-8

3.1.2. Truck Mounted System:

- The truck mounted system (232Y) shall be powered by:
 - Either a dedicated battery pack of four 6 VDC marine/RV type 4-D deep cycle lead/acid batteries,
 - Or directly from the vehicle electrical system.
 - If the dedicated battery pack is connected to the vehicle charging system, it should be isolated by installing a commercially available RV battery isolator.

3.2. Charging: The charging system for the primary power supply shall be as follows:

- The charging system for a trailer mounted sign shall be a solar system consisting of a photovoltaic array supplying electrical energy to the batteries through a solar regulator.
- The system shall provide “on demand” charging consistent with battery condition and with the solar luminance at the photovoltaic array.
- The trailer shall also be equipped with a standard 110 VAC receptacle as well as a temperature stable 110 VAC battery trickle charger and ammeter.
- The 110 VAC charging system shall initiate charging automatically when 110 VAC service is connected, and shall be capable of completely charging the battery pack within a 48 to 72 hour (nominal) time period. The actual charging time will vary depending upon conditions and state of charge/discharge of the batteries. Initiation of 110 VAC charging shall completely disconnect the solar charging capability from the charging circuit.

3.2.1. Trailer Mounted System:

Sign Model	Solar Panel Wattage	# of Panels*	Amp Rating Max Power Current (Amps)
232	80-160 Watts	1-2	4.67

*Each unit is able to hold a maximum of 2 panels

3.2.1.1 Aimstar™ Adjustable Solar Assembly (Optional):

- The solar charging system shall be adjustable to be positioned, regardless of the direction of the sign display, by the user to be angled towards the optimal solar position.
- The positioning of the solar assembly allows the power system to achieve an increased collection rate of solar power throughout normal daylight operation. This provides a 40% to 50% more efficient recharge rate to the batteries than utilizing a non-adjusting solar assembly.



3.2.2. Truck Mounted System: The truck-mounted system shall be charged from the vehicle electrical system.

4. CENTRAL PROCESSING UNIT

4.1. Description:

- The CPU shall consist of a single printed circuit board which shall contain all of the sign message memory as well as the sign operating software.
- The CPU shall be a conformal coated 100% solid state unit with no moving parts or switches, shall be operable in 0-95% non-condensing humidity conditions at temperatures from -30 degrees F to +165 degrees F, and shall include provision(s) for protection against damage should the 12 VDC power source be incorrectly connected with the leads reversed.
- The CPU shall have sufficient capacity to store 230 manufacturer-selected, pre-stored messages and up to 200 operator-defined, keyboard generated messages.
- Message memory shall be retained during power interruptions or failures, and the CPU shall be capable of operating the sign system in the event that the keyboard controller is disconnected.

4.2. CPU Location: The CPU shall be located within the sign case behind the display panels and shall be mounted on the display panel support structure.

4.3. CPU Wiring: For ease of maintenance, the CPU shall contain all of the terminal connectors for the display panel wiring harnesses and the keyboard terminal harness.

CPU:

- Processor: Amsig WEBBEXPRESS Proprietary CPU
- Ethernet Port: 10/100bT
- Temperature Range: -40°C to +85° C (-40°F - +185° F)
- Serial Port(s): 2, RS232 (Comm1 and Comm2)
- Watchdog Timer
- Display: LCD
- Keyboard Amsig TERMINAL 105
- Power Requirements: +5VDC (low current +12VDC)
- GPIO for External Temp Sensing

Data Distributor:

- The data distributor board formats and renders messages based on the incoming packets from the CPU.
- The data distributor also reads the pixel information from the display boards and sends that information to the CPU.
- The pixel feedback enables any host application that communicates with the CPU to generate a WYSIWYG interface.
- If a pixel has failed, the user will know it, since the host display will show the failed pixel.



Telemetry Card:

- The telemetry card provides system housekeeping functions.
- It connects the system via the 10/100bT Ethernet network.
- The telemetry card performs the following functions:
 - ✓ Monitors battery current up to 90 amps
 - ✓ Monitors battery voltage up to 20 volts
 - ✓ Provides digital input for photo sensor (ambient light measurement)
 - ✓ Spare A/D input
 - ✓ Four auxiliary digital inputs / outputs
 - ✓ Solar Charge Control Relays (2)
 - ✓ Connection for other 12 volt electronics

5. SIGN KEYBOARD TERMINAL

5.1. Description:

- The sign controller shall utilize industry standard VT 100 cursor control commands, shall be nominally 4.8" x 9.9" x 2.0", shall be removable, and shall be mounted within the control cabinet utilizing easily removable retainers.
- Removing the keyboard and disconnecting the electrical connections shall not interrupt the fully operational status of the sign display.
- The keyboard terminal shall consist of a standard keyboard and a backlit 4 line x 20 character /line liquid crystal display.
- The LCD characters shall be nominally 0.2" in height.
- The terminal shall be weather-tight, shall be manufactured with conformal-coated circuit boards capable of operation in 0-95% non-condensing humidity conditions, and shall be rated for operation from -30 degrees F to +165 degrees F.

5.2. Location:

5.2.1. Trailer Mounted System: On a trailer mounted sign system, the keyboard terminal shall be located in the control cabinet, mounted with easily removed retainers, and detachable from the electrical umbilical connector while maintaining sign operation.

5.2.2. Truck Mounted System: On a truck mounted sign system, the keyboard terminal shall be located in the cab of the vehicle at the customer's convenience and shall be connected to the sign display via an electrical umbilical connection at the bottom of the sign case. A small hand held keyboard terminal shall be available for truck-mounted signs.



6. SIGN OPERATING SOFTWARE

6.1. Description: The sign operates through a menu driven system which allows the user to input commands using standard keystrokes to generate messages, message pages, review diagnostics, and generate operation schedules. The sign operating system shall perform the minimum items:

- Password Protected: Multi-levels, User, Maintenance / Factory Diagnostic
- NTCIP Compliant V1203 standard objects
- Sign Diagnostics
- Battery Voltage
- Charging Voltage (Landline & Solar)
- Component Failure Status
- Adjust Brightness levels
- Message Scheduling
- Additional component use (e.g. Radar, Cellular)

6.2. Changeable Messages:

- The editing feature shall provide the operator the ability to change messages and/or message sequences utilizing either the pre-stored messages or the operator/keyboard entered messages.
- If operator generated messages are entered, the message shall be displayed on the keyboard LCD. Unless lower case letters are specifically entered utilizing the "shift" key, all letters shall be upper case.
- It shall also be possible to "blink" one or more lines of any operator generated message.
- The editing feature shall also enable the operator to choose among eleven pre-selected character fonts for the sign display as denoted below.
- The utilization of these fonts shall result in legibility distances as indicated in the following table:

Font	Nominal Height	Character/Line	Lines/Sign Face	Legibility Distance
3 x 5	5"	18	4	300 ft.
4 x 5	5"	14	4	300 ft.
3 x 7	7"	18	3	400 ft.
4 x 7	7"	14	3	400 ft.
5 x 7	7"	12	3	500 ft.
5 x 7W	7"	10	3	500 ft.
7 x 7	7"	9	3	500 ft.
7 x 7W	7"	8	3	500 ft.
6 x 11	10.5"	10	2	650 ft.
7 x 20	19"	9	1	1,000 ft.
9 x 20	19"	7	1	1,100 ft.

6.3. Graphics: Graphics capability shall be available from the keyboard and shall include full sized chevrons, dynamic moving arrows (left and right), small directional arrows, and 26 symbol messages from Part VI of the MUTCD.



7. SIGN CASE

7.1. Description:

- The sign case shall be of all aluminum construction fabricated utilizing ASTM B 209 6063-T5 extrusions and 3003-H14 sheet material.
- Case Dimensions – 34” High X 71” Wide
- The case shall be nominally 7” in thickness and conform to the list matrix below.
- The sign case shall be painted flat black on all interior and exterior surfaces.

7.2. Lens:

- The lens shall consist of a single piece of polycarbonate plastic that shall serve as the front of the sign case and shall be hinged at the top to facilitate access to the interior of the case for servicing of the sign.
- The lens shall be 1/4” in thickness per accepted plastic industry convention and shall be suitably stabilized to resist degradation due to exposure to ultraviolet (UV) radiation.
- Each pixel shall be provided with an unscreened window while the remainder of the lens (nominally 63%) shall have the front surface screened with a flat black ink to reduce glare from ambient solar illumination or from vehicle headlights.

7.3. Sign Case Housing: The sign case shall contain the display panels, the CPU, the display power supply, wiring harnesses, and the photocell.

8. SIGN SUPPORT

8.1. Description: The configuration of the actual support structure will be dependently variable as the type of vehicle upon which the sign is transported and/or displayed varies.

8.2. Vehicle Type:

- The sign may be transported and displayed on a dedicated trailer that accommodates the 12 VDC power source batteries and the combination of solar and 110 VAC charging systems.
- Alternatively, the sign may be transported and/or displayed on a pick-up or flat bed truck with one of several support structures.

8.2.1. Trailer Mounted:

- If trailer mounted, the raising and lowering mechanism shall approximate that of an electro-hydraulic cylinder center pole vertical mast or an optional manually-operated winch & pulley system.
- The solar array shall be mounted on a level mechanism such that the array is maintained in a horizontal plane regardless of the position of the sign case.
- The pivot mechanism shall be constructed such that a single operator can deploy the display and the solar array simultaneously while maintaining proper positioning of the array.
- The raising/lowering of the display can be facilitated by an optional electric hydraulic cylinder mast rated for 2,000 lbs..
- The height of the trailer mounted sign in the transport mode shall be 97” to the top of the solar array, and in the display mode, 132” to the top of the solar array.



8.2.2. Truck Mounted:

- The sign may be mounted permanently or semi-permanently on a truck by bolting the sign support structure to the bed floor or walls.
- The sign may also be mounted temporarily utilizing a skid mount that fits in the bed of the vehicle.
- With any mounting configuration, it is recommended that the support structure accommodate tilting the sign to a horizontal position for transporting and to a vertical, or nearly vertical, position for display.

9. TRANSPORT VEHICLE

9.1. Trailer: For trailer-mounted signs, the trailer shall meet the following requirements:

9.1.1. Description:

- The trailer shall be nominally 103" in length with the removable tongue in place and 63" in width.
- Trailer length with tongue retracted (storage position) is 81."
- Outrigger supports will extend the length 18" rearward when parked.
- It shall be constructed of 3" x 3" steel tube (ASTM A 500 Grade B) with 1/8" wall thickness and shall be welded in accordance with applicable American Welding Society (AWS) standards.
- The trailer shall have a lockable, weatherproof control cabinet housing the keyboard terminal, control panel, and a lockable battery box for the 12 VDC power source batteries.
- The trailer shall be finished with a two-coat automotive paint process to protect it from weather and road hazards.

9.1.2. Rating:

- The axle shall be rated for 2000 pounds, the springs for 1300 pounds each set, and the wheels shall be 13' steel with 5 lugs bolts per wheel and fitted with 175-60-13 C rated tires.
- The removable tongue shall be fitted with a 2" ball coupler rated for 5000 pounds.
- Standard axle is leaf spring, customer may upgrade to a torsion suspension system if required.

9.1.3. Removable Tongue:

- The removable tongue shall be fabricated from 3" x 3" steel tube (ASTM A 500 Grade B) with 3/8" wall thickness, shall be affixed to the body of the trailer with a retaining pin positioned in the floor of the battery box, and shall have safety chains attached.
- The lighting lead shall be affixed permanently to the tongue and shall separate from the trailer wiring harness at a plug connector when the tongue is removed.

9.1.4. Stabilizing Outriggers:

- Each corners of the trailer shall be fitted with screw jacks to stabilize the trailer when in the display position.
- The screw jacks shall pivot to a horizontal position for transport.

9.2. Trucks: The sign system may be mounted on a variety of vehicles ranging from full size pick-ups to flatbeds, long line strippers, etc. Mounting specifications will vary with the transport vehicle.



10. OPTIONS Remote Communications, Radar, Highway Advisory Radio (HAR), & ITS Devices

10.1. Description: The sign may be equipped with any of the following devices for communications, data acquisition, and/or information dissemination.

10.2. Remote Communications: The sign system shall be equipped so as to provide for host computer/remote sign interaction through a landline telecommunication / modem link, or digital cellular transceiver. In addition to using NTCIP-compliant software-based interfaces, the sign may be controlled via website provided it has remote communications with static IP Based cellular link.

10.3 Radar Transducer: A Doppler-effect microwave radar transducer can be outfitted to the message sign to provide the sign with added traffic calming capabilities. These abilities include: Instantaneous speeds of front most and fastest target or activation of an overspeed sequence, which automatically interrupts current sequence.

10.4 Radar Data Logging Capability: Sign used in conjunction with Radar Option and Cellular Communications Software Option can be utilized to collect traffic data such as average speeds, 85th percentile, 50th percentile, and average # of cars. All data is presented in graph format accessed within the software.

10.5 Highway Advisory Radio (HAR): The Highway Advisory Radio option allows the user to record an audible message to a locally mounted AM band transmitter (tuned to State specific frequency). Up to 8 messages can be played in continuous loop, while providing for storage of other messages with respect to size of digital recorder/player.

10.6 Queue Detection: American Signal Changeable Message Signs are able to be paired with an American Signal Queue Detection Trailer and connected wirelessly to be able to instantly display a condition responsive sequence of messages pre-set by the user.

10.7 Aimstar™: This option outfits the signs with an adjustable solar assembly. Through positioning the solar assembly aimed toward the southern hemisphere, the unit is able to receive an increased rate of charge for the battery bank.

10.8 ITS Related Options: The Advantage Series message signs can be outfitted with most of the common ITS elements. The items include; CCTV, RWIS, RTMS, etc... American Signal is also able to provide custom integration solutions for products not mentioned.

10.9 Expanded Power Configurations: The Advantage Series models can be outfitted with additional batteries and solar panels.

10.10 Wireless handheld terminal: The handheld terminal can be equipped with a Bluetooth radio to allow for untethered operation of the sign.

10.11 Hand Crank: A manually operated mast raising and lowering mechanism is an optional downgrade.

10.12 Miscellaneous: American Signal is able to meet the user's needs for additional hardware items. We are able to provide any hitch type (Ball, Pintle or Lunette Eye, Bulldog, Adjusting Height, etc...), axle type, lift requirements, color specifications, alarms, etc.



Note of Application: *This specification is widely applicable to catalog items AMS30062800, AMS30062801, AMS30062810, AMS30062815, AMS30155200, AMS30155201, AMS30062325, AMS30062326. Catalog designations and this specification are subject to change without notice.*