

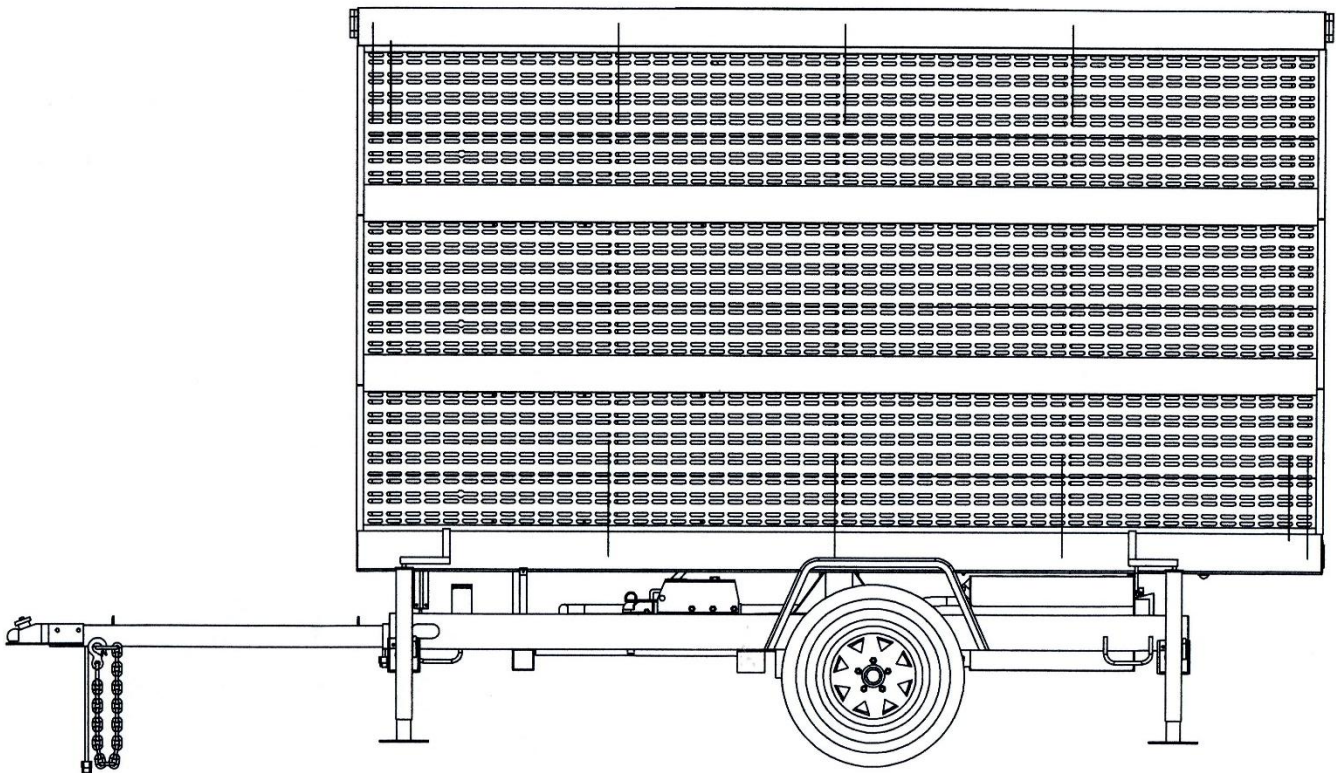

CMS-T332 Line Matrix Display

Solar Charged, Battery Powered All LED
Portable Changeable Message Sign

Product Specifications





2755 Bankers Industrial Drive
Atlanta, GA 30360
Phone: 770-448-6650
Fax: 770-448-8970

1. SCOPE

This specification defines the characteristics and features of a portable changeable message sign. This system allows the user to display a message on a sign display to inform motorists and the traveling public of oncoming road conditions and advisories.

- The display format for the sign display is Line Matrix.
- The sign is battery powered with both solar and 110 VAC charging systems.
- The sign system may, as an option, be equipped for remote operation through remote communications; cellular, RF wireless, CDPD, Satellite, etc...
- The sign system may also be utilized to display dynamic, in situ traffic speeds through use of the optional traffic radar transducer and resident software, or may display downstream traffic congestion information utilizing optional queue detection in conjunction with resident software.
- These portable signs can also be used as a platform and power source for many Intelligent Transportation System (ITS) devices including; CCTV, HAR, & RWIS
- Meets or exceeds standards set forth in:
 - FHWA
 - MUTCD
 - NTCIP Version 2

IMPORTANT FEATURES:

- Heavy duty all steel welded trailer frame to ensure long life and excellent durability
- Two-coat automotive paint process to protect it from weather and road hazards
- Single piece polycarbonate plastic lens for each row of LED panels with front surface screened matte black to reduce glare

2. MESSAGE SIGN DISPLAY

2.1 Description:

- The CMS-T332 is a twenty-one (21) pixel row by fifty (50) column, Line Matrix, LED Display.
- Each display shall be configured of all light emitting diode (LED) with each having operational characteristics of Amber 590nm LEDs with a 30° cone of angularity.
- The display shall consist of three lines, each of which shall contain ten (10) display panels.
- Panel size - 19.4" high by 12.6" wide
- The display panels shall be uniformly spaced horizontally across the display face.
- Each line of display has a pixel configuration of 7 pixel rows high by 50 pixel columns wide.
- Each line is vertically separated by a space of 6-inches. A 6-inch contrast border is located at the top and bottom of the display.

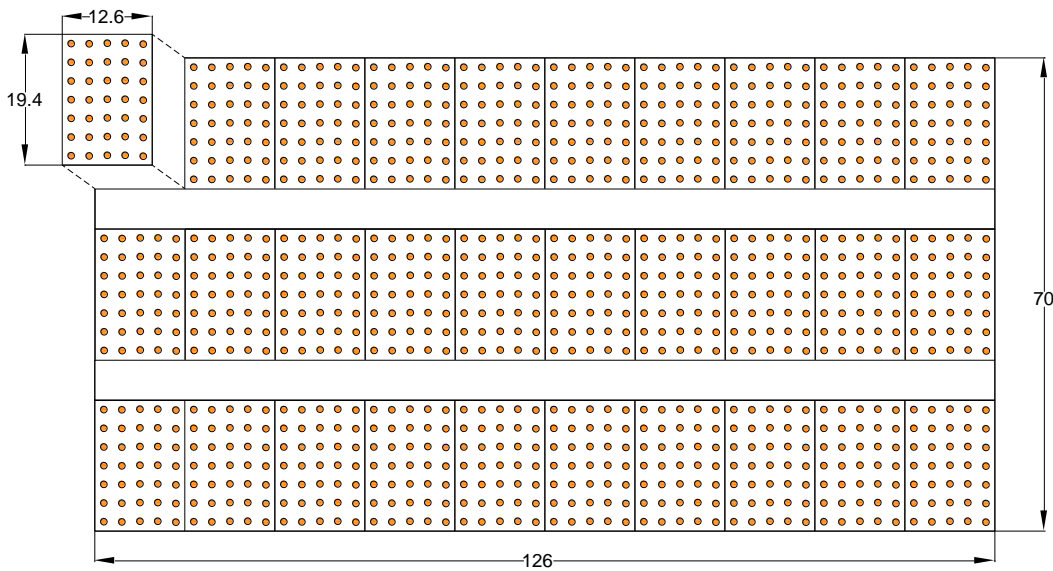

2.2 Display Panels:

- Display panels shall be 100% solid state with no moving parts and shall be identical to, and mutually interchangeable with, all other panels.
- No field hardware or programming modifications shall be required to exchange or replace individual display panels.
- Each display panel shall contain the LED driver circuitry necessary to operate its associated LED's.
- There shall be no separate driver boards between the display panels and the central processing unit (CPU).
- Each individual panel shall have the following layout characteristics specific to the sign type.
 - 4 LEDs per Pixel
 - Pixel Layout per Panel – 7 Rows X 5 Columns
 - Pixel Spacing – 2.80" High X 2.70" Wide
 - LED Angularity – 30 degrees
- Each panel shall be able to monitor and determine pixel failure.
- Pixel failure will be represented on host software and local control system identifying location of failed pixel.
- Controller display will be in WYSIWYG format, (What You See Is What You Get.).



2.3 LED Pixels:

- An individual pixel shall consist of four Dynapoint™ lens enhanced LED's spaced on 1.0" centers both vertically and horizontally.
- The LED's shall be ITE amber wide angle providing for both daylight and nighttime legibility and shall be rated for a service life of 100,000 hours, and shall have an operating temperature range of – 40° F. to + 165° F.
- General Characteristics:
 - Number of Pixels: 35 standard, 7 pixels rows, 5 pixel columns
 - Number of LED's per pixel: 4 standard
 - Operating Voltage: 12VDC nominal
 - Brightness Control: Pulse width modulation
 - Current Limiting: One external resistor per driver
 - Pixel Feedback: Differential amplifier per pixel (where provided)
 - Feedback Logic: CPLD on-board
 - Column Decoding: CPLD on-board
 - Optics: Dynapoint™ Lens System
 - LED Driver: Power shift register technology with programmable current limit
 - Temperature Range: -40° F to +165° F

Font	Nominal Height	Nominal Width	Characters per Line	Lines per Display	Legibility Distance
3 x 7	18"	8"	12	3	900'
4 x 7	18"	10"	8	3	1,000'
5 x 7	18"	12"	8	3	1,250'

2.4. Display Power Supply:

- The power supply for the display shall be sufficient to operate the LED pixels for both daylight and nighttime conditions.
- It shall be suitably regulated and temperature stable.



2.5. Panel Wiring:

- The display panel wiring shall be comprised of one wiring harness for each column of display panels with positive locking connectors at the CPU and at the individual display panels.
- The harnesses shall be comprised of twenty gauge, or larger, individual conductors (no ribbon cables), and shall be configured so as to preclude data from a malfunctioning display panel column being transmitted to and corrupting any other display panel column in the sign display.

3. 12 VDC POWER SOURCE

3.1 Description: The 12 VDC power source for the system shall be a battery pack charged primarily by a solar array that provides virtual autonomy for the system.

3.2 Battery Pack:

- The battery pack shall consist of 6VDC deep cycle golf cart type lead /acid batteries (BCI Group GC-2) that when in a fully charged condition shall provide sufficient electrical energy for the continuous and proper operation of the sign system for a nominal period of thirty days without the necessity of recharging.
- Warranty service for the batteries shall be locally available on a nationwide basis from the batteries manufacturer.
- A 110 VAC charging system is also standard on all units and available for landline operation of the system.
- Control of the sign power supply shall be provided by a power management system that shall regulate the charging of the batteries by the solar charging system, and shall provide for temperature compensation, regulation, and distribution of power to the various sign functions.
- The charging of the 12 VDC power source batteries shall be independent of the position of any switch on the control panel.

3.3 Charging:

- The sign system shall be equipped to provide for the charging of the 12 VDC power source batteries by either a solar charging system, or alternatively, by a 110 VAC charging system.

3.3.1 Solar Charging System:

- The solar charging system shall consist of a photovoltaic array mounted at the top of the sign case and a power management system.
- The system shall provide regulated, “on demand” charging consistent with battery condition, with the ambient solar luminance at the photovoltaic array, and with net power consumption within the sign system.
- Charging of the batteries shall be independent of the position of any switch on the control panel. Initiation of 110 VAC charging service shall completely disconnect the solar array from the charging circuit.

3.3.1.1 Aimstar™ Adjustable Solar Assembly (Optional):

- The solar charging system shall be adjustable to be positioned, regardless of the direction of the sign display, by the user to be angled towards the optimal solar position.
- The positioning of the solar assembly allows the power system to achieve an increased collection rate of solar power throughout normal daylight operation. This provides a 40% to 50% more efficient recharge rate to the batteries than utilizing a non-adjusting solar assembly.



3.4 110 VAC Charging System:

- The 110 VAC charging system, supplied as standard equipment, shall consist of a temperature compensating, 110 VAC input battery trickle charger, an ammeter for monitoring the charging process, and an electrical receptacle mounted on the control pedestal.
- The system shall be configured so as to initiate charging of the power supply batteries when the 110 VAC service is connected without the necessity of operator intervention, and shall be capable of completely charging the battery pack within a 24 to 72 hour time period.
- The actual charging time will vary depending upon conditions and state of charge/discharge of the batteries.

4. CENTRAL PROCESSING UNIT

4.1 Description:

- The CPU shall consist of a single printed circuit board, which shall contain all of the sign message memory as well as the sign operating software.
- The CPU shall be conformal coated, 100% solid-state unit with no moving parts or switches.
- It shall be operable in 0-95% non-condensing humidity conditions at temperatures from -30 degrees F to +165 degrees F.
- The CPU shall have sufficient capacity to store 230 manufacturer-selected, pre-stored messages and up to 200 operator-defined, keyboard generated messages.
- Message memory shall be retained during power interruptions or failures, and the CPU shall be capable of operating the sign system in the event that the keyboard controller is disconnected.

4.2. CPU Location: The CPU shall be located within the sign case behind the display panels and shall be mounted on the display panel support structure.

4.3. CPU Wiring: For ease of maintenance, the CPU shall contain all of the terminal connectors for the display panel wiring harnesses and the keyboard terminal harness.

CPU:

- Processor: Amsig WEBBEXPRESS Proprietary CPU
- Ethernet Port: 10/100bT
- Temperature Range: -40°C to +85° C (-40°F - +185° F)
- Serial Port(s): 2, RS232 (Comm1 and Comm2)
- Watchdog Timer
- Display: LCD
- Keyboard Amsig TERMINAL 105
- Power Requirements: +5VDC (low current +12VDC)
- GPIO for External Temp Sensing



Data Distributor:

- The data distributor board formats and renders messages based on the incoming packets from the CPU.
- The data distributor also reads the pixel information from the display boards and sends that information to the CPU.
- The pixel feedback enables any host application that communicates with the CPU to generate a WYSIWYG interface.
- If a pixel has failed, the user will know it, since the host display will show the failed pixel.

Telemetry Card:

- The telemetry card provides system housekeeping functions.
- It connects the system via the 10/100bT Ethernet network.
- The telemetry card performs the following functions:
 - ✓ Monitors battery current up to 90 amps
 - ✓ Monitors battery voltage up to 20 volts
 - ✓ Provides digital input for photo sensor (ambient light measurement)
 - ✓ Spare A/D input
 - ✓ Four auxiliary digital inputs / outputs
 - ✓ Solar Charge Control Relays (2)
 - ✓ Connection for other 12 volt electronics

5. SIGN KEYBOARD TERMINAL

5.1 Description:

5.1.1 Handheld Controller (Standard):

- The Hand-Held Terminal (HHT) shall utilize industry standard VT 100 cursor control commands, shall be nominally 4.8" x 9.9" x 2.0", shall be removable, and shall be mounted within the control cabinet utilizing easily removable retainers.
- Removing the controller and disconnecting the electrical connections shall not interrupt the fully operational status of the sign display.
- The controller terminal shall consist of an alphanumeric controller with a backlit 4 line x 20 character /line liquid crystal display.
- The LCD characters shall be nominally 0.2" in height.
- The terminal shall be weather-tight, shall be manufactured with conformal-coated circuit boards capable of operation in 0-95% non-condensing humidity conditions, and shall be rated for operation from -30 degrees F to +165 degrees F.

5.1.2 OPTIONAL CONTROLLER INTERFACE (ITS MODEL)

- Standard PC104 QWERTY keyboard w/ integrated mouse
- Full Color quarter VGA LCD screen capable of displaying and mimicking display.



6. SIGN OPERATING SOFTWARE

6.1 Description: The sign operates through a menu driven system which allows the user to input commands using standard keystrokes to generate messages, message pages, review diagnostics, and generate operation schedules. The sign operating system shall perform the minimum items:

- Password Protected: Multi-levels, User, Administrator, Maintenance / Factory Diagnostic
- NTCIP Compliant V1203 standard objects
- Sign Diagnostics
- Battery Voltage
- Charging Voltage (Landline & Solar)
- Individual Pixel Feedback
- Component Failure Status
- Adjust Brightness levels
- Message Scheduling
- Additional component use (e.g. Radar, Cellular)

6.2. Changeable Messages:

- The editing feature shall provide the operator the ability to change messages and/or message sequences utilizing either the pre-stored permanent messages or the operator/keyboard entered changeable messages.
- If operator generated messages are entered, the message shall be displayed on the keyboard LCD. Unless lower case letters are specifically entered utilizing the "shift" key, all letters shall be upper case.
- It shall also be possible to "blink" one or more lines of any operator generated message.
- The editing feature shall also enable the operator to choose among nine pre-selected character fonts for the sign display as denoted below.
- The utilization of these fonts shall result in legibility distances as indicated in the following table:

Font	Nominal Height	Nominal Width	Characters per Line	Lines per Display	Legibility Distance
3 x 7	18"	8"	12	3	900'
4 x 7	18"	10"	8	3	1,000'
5 x 7	18"	12"	8	3	1,250'

* unit has ability to store up to 20 defined fonts

6.3 Graphics: Per NTCIP V1203, line-high moving arrows can be inserted into Changeable Messages. Graphics for a line matrix display are not supported by NTCIP V1203.



7. SIGN CASE

7.1 Description:

- The sign case and trailer frame shall be completely designed and fabricated from metal.
- The sign case shall be aluminum and the trailer frame shall be steel.
- The sign case shall be equipped with a bottom-mounted sight tube for optimal display alignment.
- An electric hydraulic mast is supplied to raise the display from travel mode into display mode.
- A backup hand pump for the hydraulic mast is included as standard.
- The display shall have a silk-screened polycarbonate lens system to improve conspicuity of display in standard operation conditions.

7.2 Lenses:

- Polycarbonate lenses shall serve as the front of the sign case (three lenses for CMS-T332 model) and shall be removable by sliding to either side to facilitate ease of internal service.
- The lenses shall be 3/16 " in thickness per accepted plastics industry convention, shall be suitably stabilized to resist degradation due to exposure to ultraviolet (UV) radiation.
- The lens shall have the front surface screened with a flat black ink to reduce glare from ambient solar illumination or from vehicle headlights.
- The screening pattern shall be consistent with the position of the LED pairs in the display and provide for the viewing of only the illuminated pixels during message display.

7.3 Sign Cabinet

- The sign case shall be of all aluminum construction fabricated utilizing ASTM B 209 6063-T5 and 6061-T6 aluminum extrusions and 3003-H14 aluminum sheet material with aluminum and/or stainless steel fasteners and plastic lenses.
- The case shall be 137.75 " in width (139.75" with running lights), 79.5" in height, and nominally 6.2" in thickness.

8. SIGN SUPPORT

8.1 Description: The mounting post shall support the sign case in a vertical position and serve as an integral part of a system facilitating the vertical and rotational movement of the sign case.

- The post assembly shall consist of two concentric round steel tubes, the inner (lower) being 5 1/2" OD x 3/8" wall steel (ASTM A 513), and the outer (upper) 6" OD x 3/16" wall.
- The post assembly and attendant hydraulic cylinder shall enable the operator to raise the bottom of the sign case to a minimum height of 7 feet above the surface of the roadway, and to rotate the sign case through 360 degrees.
- A positive brake assembly shall be provided to prevent unwanted movement once the sign case is in the desired display position.
- A mast safety pin shall be provided to prevent the sign case from falling in the event of a hydraulic system failure.



8.2 Hydraulic System:

- A hydraulic cylinder shall be encased within the inner (lower) portion of the post assembly and shall be used to raise the outer (upper) portion and attached sign case.
- The cylinder shall be driven by an electrically powered hydraulic pump (with attached fluid reservoir) controlled by the UP/DOWN toggle switch on the control panel.
- The hydraulic system shall include an auxiliary manual pump with release for emergency use.

9. TRANSPORT VEHICLE

9.1 Description:

- The trailer shall be nominally 159 inches in length with the removable tongue in place and 79.2 inches in width.
- The trailer shall be nominally 188 inches in length if the optional expanded power configuration beyond 8X is chosen.
- Trailer length with tongue removed (storage position) shall be nominally 138" regardless of configuration.
- It shall be constructed of 3"x3" and 3"x 5" steel tube (ASTM A36) with 3/16" wall thickness, and shall be welded in accordance with applicable American Welding Society (AWS) standards.
- The trailer shall have a lockable, internally illuminated, weatherproof equipment cabinet housing the keyboard terminal and control panel.
- The trailer shall also have a lockable pump housing for the hydraulic pump, and lockable battery box for the power source batteries. Optional expanded battery bank may require an additional lockable battery box.
- The trailer shall have a single axle with dual axles as an option, and a fixed height ball hitch (fixed height tow ring and adjustable height ball or tow ring hitches optional).
- The trailer shall be finished with a two-coat automotive paint process to protect it from weather and road hazards

9.2 Rating:

- The trailer and springs and axle shall be rated for 3500 pounds.
- The removable tongue assembly with optional hydraulic surge brakes shall be constructed from 3" x 3" steel tube (ASTM A 36) with 3/8" wall thickness, rated for 6000 pounds, and fitted with a 2" ball hitch.
- Wheels shall be 15" steel with 5 lug bolts per wheel and fitted with P 205-75-15 B rated tires.

9.3 Removable Tongue:

- The removable tongue shall have safety chains attached.
- No tools shall be required for removal or remounting of the tongue.
- It shall not be necessary to disconnect any optional hydraulic brake lines to effect complete removal, and it shall not be necessary to bleed the optional brake system upon re-installation of the tongue.
- The lighting lead shall be affixed permanently to the tongue and shall separate from the trailer wiring harness at a plug connector when the tongue is removed

9.4 Leveling Jacks:

- The trailer chassis shall have at each corner a 2000 pound leveling jack affixed in such a manner that the jacks may be readily placed and locked in a horizontal position for traveling without necessitating the use of any tools.
- The trailer and sign assembly, when stationary and supported properly with the leveling jacks shall withstand AASHTO rated 100 MPH wind gusts.



10. OPTIONS

10.1 Description: The sign may be equipped with various Intelligent Transportation System (ITS) devices to provide for remote operations, sensor control or activation, and conditional response.

10.2 Remote Communications: The sign system shall be equipped so as to provide for host computer/remote sign interaction through either a landline telecommunication / modem link or digital cellular transceiver. Rather than software based, the sign may be controlled via website provided it has remote communications with static IP Based cellular link.

10.3 Amsig ITS Cloud Manager Software: The Amsig ITS Cloud Manager software package shall enable the sign to be contacted via user's choice of remote communication. In addition, this software is presented in a graphical user interface (GUI) format allowing the user to select the appropriate sign on the screen for communications.

10.4 Radar Transducer: A Doppler effect microwave radar transducer can be outfitted to the message sign to provide the sign with added traffic calming capabilities. These abilities include: Instantaneous speeds of front most and fastest target or activation of an overspeed sequence, which automatically interrupts current sequence.

10.5 Voicestar™ Highway Advisory Radio: The sign may be outfitted with an optional Highway Advisory System which broadcasts an audio message on the AM band in either low or high frequency. Up to 8 messages can be played in continuous loop, while providing for storage of other messages with respect to size of digital recorder/player.

10.6 Aimstar™: This option outfits the signs with an adjustable solar assembly. Through positioning the solar assembly aimed toward the optimal solar position, the unit is able to receive an increased rate of charge for the battery bank.

10.7 Queue Detection: American Signal Changeable Message Signs are able to be paired with an American Signal Queue Detection Trailer and connected wirelessly to be able to instantly display a condition responsive sequence of messages pre-set by the user.

10.8 Wireless handheld terminal: The handheld terminal can be equipped with a Bluetooth radio to allow for untethered operation of the sign.

10.9 ITS Related Options: The Advantage Series message signs can be outfitted with most of the common ITS elements. The items include; CCTV, RWIS, RTMS, etc... American Signal is also able to provide custom integration solutions for products not mentioned.

10.10 Expanded Power Configurations: The T333 can be outfitted with additional batteries and solar panels. (Standard battery configuration for the T332 is 6X – Batteries over 8 will require an extended trailer – See paragraph 9.1)

10.11 Miscellaneous: American Signal is able to meet the user's needs for additional hardware items. We are able to provide any hitch type (Ball, Pintle or Lunette Eye, Bulldog, Adjusting Height, etc...), axle type, lift requirements, color specifications, alarms, extendable outriggers, etc.

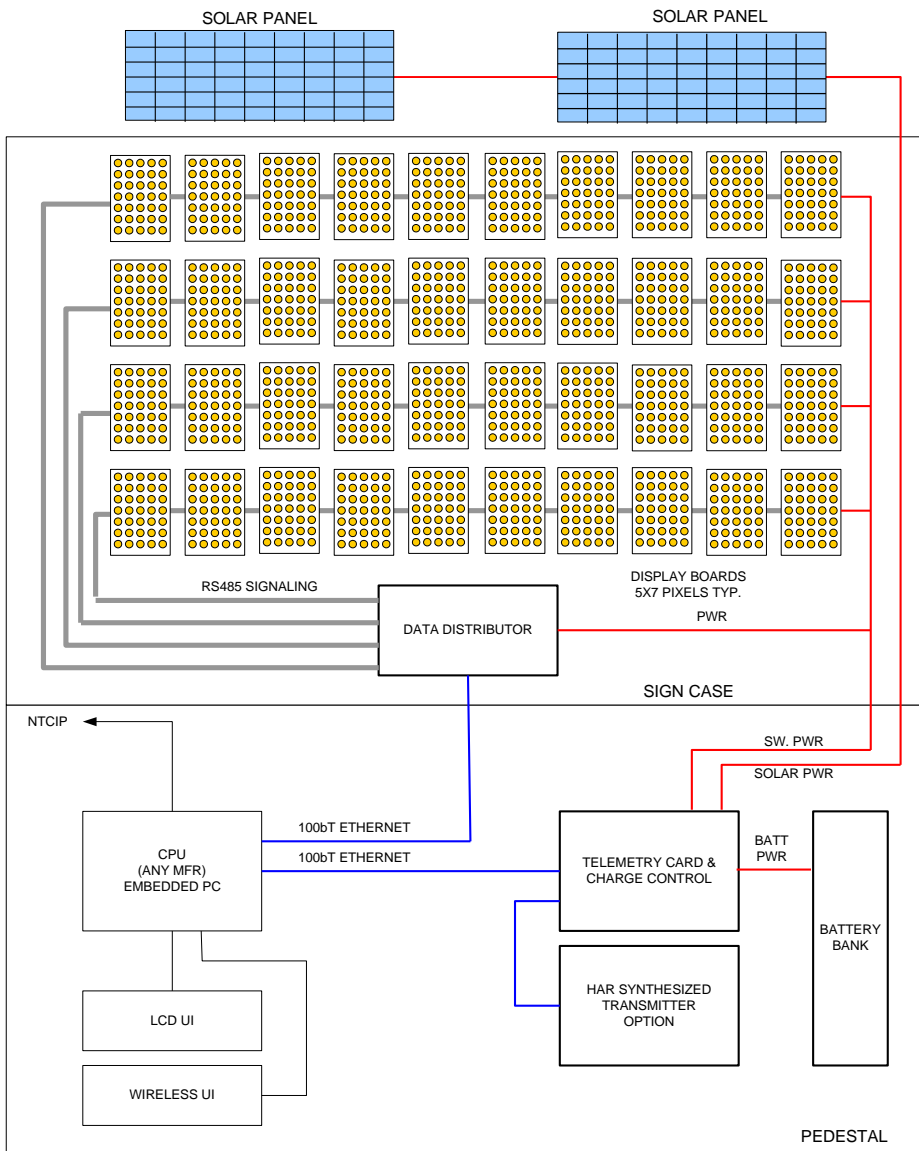

FIGURE #3 - REVISED TRAILER ARCHITECTURE BLOCK DIAGRAM

Note of Application: This specification is widely applicable to catalog items AMS30065266, AMS30065267, AMS30065268, AMS30065269, AMS30067402, AMS30067452. Catalog designations and this specification are subject to change without notice.