



# BroadView 2 Video Camera Trailer

Mobile Power Plant with CCTV, Onboard Recording, and Streaming Video

CATALOG NO:  
**AMS30065950**



**CCTV Video and Imaging** for work zone surveillance and mobile security. Amsig's BroadView 2 helps you ensure work zone compliance when placed in your work zone. Protect yourself from liability with video proof of lane closures, equipment placement, and more. Protect your people, property, and facilities by placing Amsig's BroadView 2 in position to monitor all of them.

**FEATURES** on every BroadView 2 solution:

- Battery Power – up 20x6VDC
- Solar Recharging – up to 420W
- Multi-Stage Electro-Hydraulic Mast
- Easily Deployable
- High Quality Steel and Aluminum Trailer
- Environmentally Sound

**FULL FEATURE PTZ DOME CAMERA**

mounted to the mast of our T524 Multi-Stage Mast Trailer will give you the coverage and detail you desire for security and surveillance. The Vivotek Speed Dome Network Camera\* gives you up to 20x Zoom, up to 60fps, 2MP or Full HD resolution, Extreme Weatherproofing, day/night visibility, and an onboard SDHC card slot. Amsig can also provide optional expanded onboard storage with an integrated DVR/NVR. Securely remotely operate your camera, stream video, or access onboard recordings via an integrated cellular modem. We can provide a modem for any major carrier.

*\* Other camera options are available so Amsig can address your particular needs – 3M, Bosch Cohu, WTI, and more!*

The BroadView 2 Video Camera Trailer from American Signal Company is a multi-functional necessity to complete your work zone or security application. The PTZ dome camera and communications system can monitor traffic for volume/occupancy/speed and relay data to an ITS work zone system, and provide crucial intelligence for incident management. Utilize onboard storage while also streaming your feeds. The BroadView 2 is suitable for any environment needing a highly portable platform.

**GSA GS-07F-0339L**



2755 Bankers Industrial Dr. Atlanta, GA 30360  
PHONE: 770.448.6650 FAX: 770.448.8970  
info@amsig.com / [www.amsig.com](http://www.amsig.com)



PHYSICAL / MECHANICAL	
Height (mast raised)	Up to 26' / 8m
Height (storage)	96" / 2.33m
Length (w/ tongue)	199" / 5.05m
Length (w/o tongue)	145" / 3.68m
Width	79" / 2m

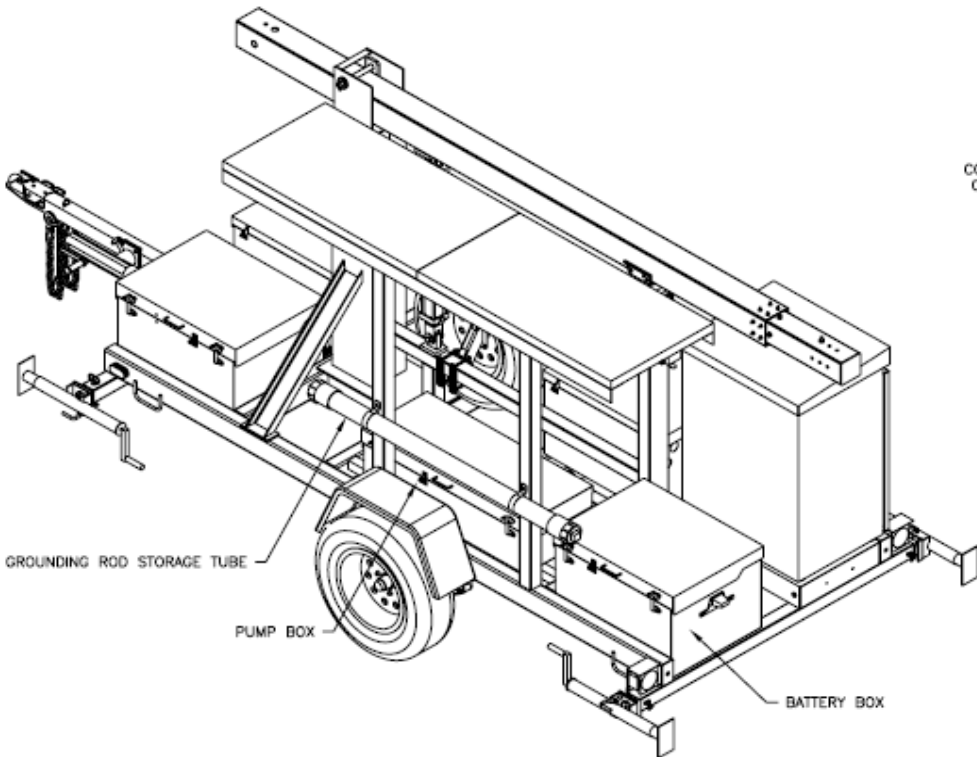
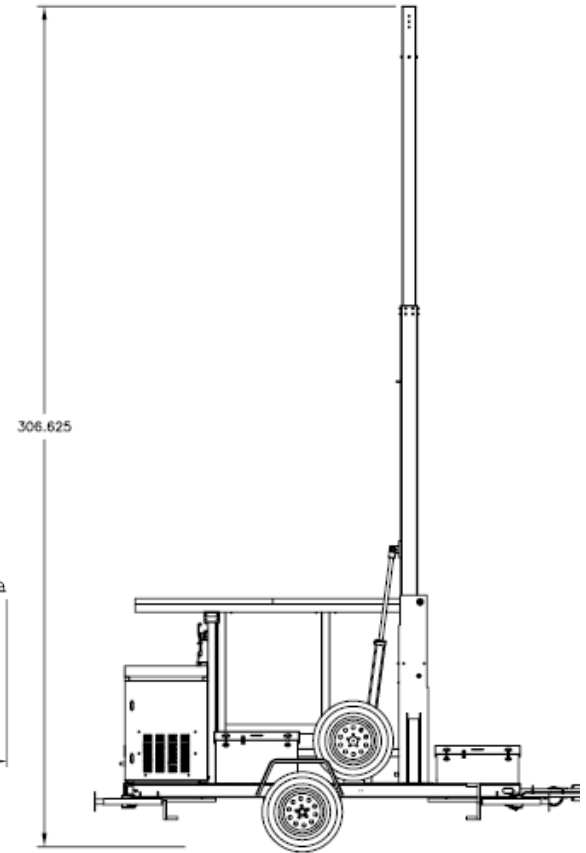
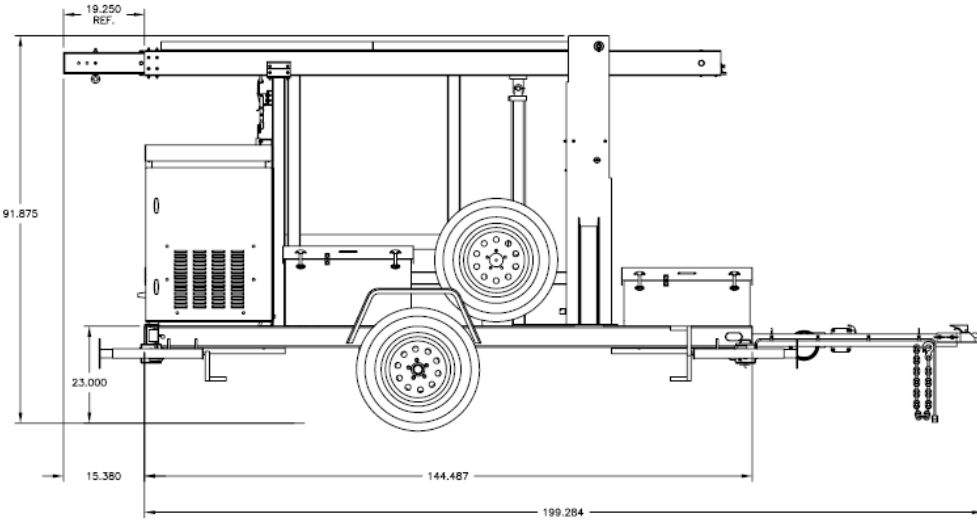

CON  
CA

American Signal Company's state-of-the-art manufacturing facility in Atlanta, GA can accommodate custom builds from the most finely-detailed construction to the most robust platform available. The T524 Multi-Stage Mast Trailer will round out your work zone or security needs. Let us learn how we can tailor-make your ideal portable solution! Call us at 770.448.6650 or visit us online at [www.amsig.com](http://www.amsig.com)

**GSA** GS-07F-0339L



2755 Bankers Industrial Dr. Atlanta, GA 30360  
 PHONE: 770.448.6650 FAX: 770.448.8970  
 info@amsig.com / [www.amsig.com](http://www.amsig.com)